

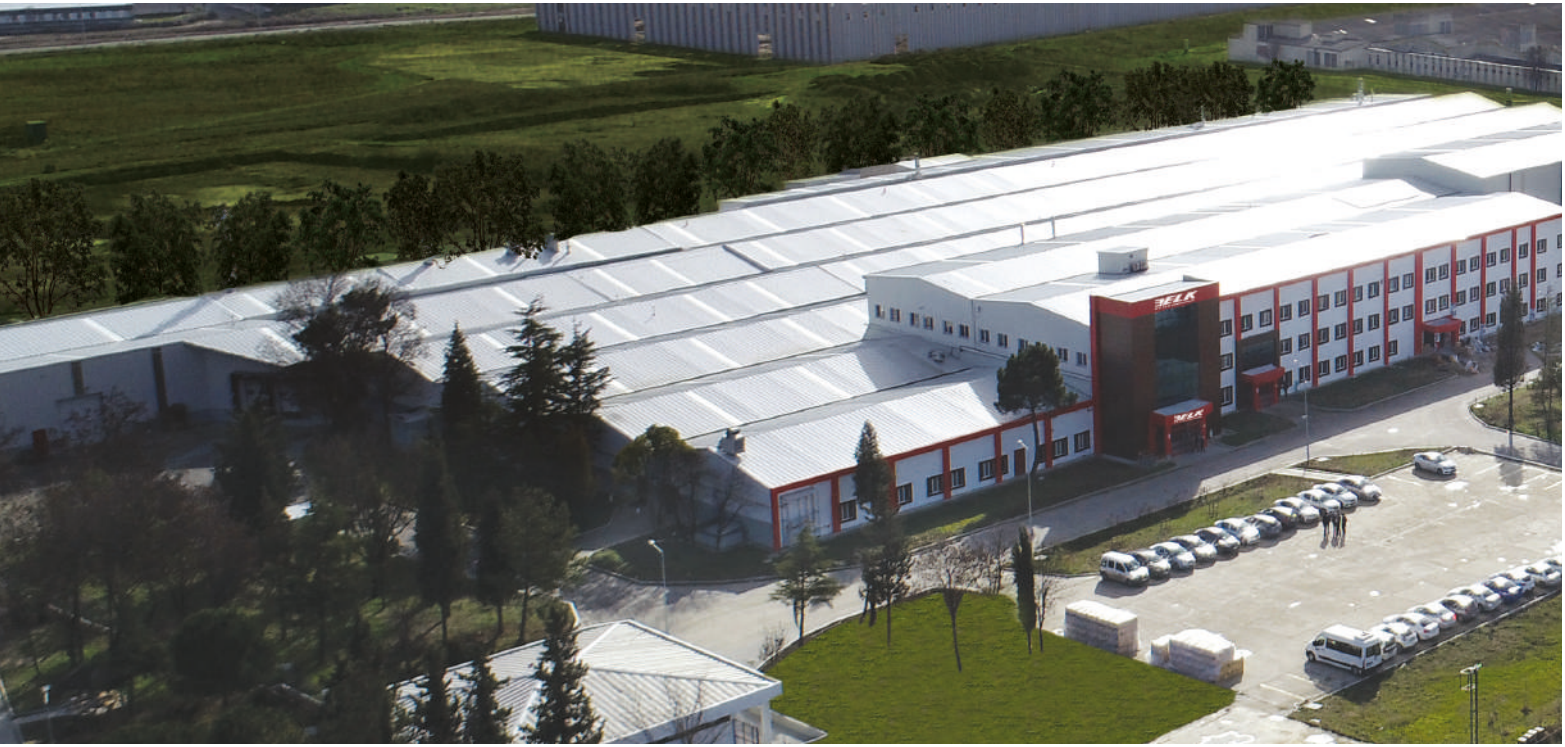

# PRODUCT CATALOGUE

ELK 1000-0725

# 2025





ELK Motor is on a mission to establish itself as a global brand by embracing its core values of environmental and human sensitivity, innovation, and technology. This mission is driven by a commitment to sustainability and the careful consideration of limited global resources. ELK Motor strives to achieve this by delivering eco-friendly, innovative, competitive, and highly efficient products.

Founded by the major shareholders of Yılmaz Redüktör A.Ş., ELK Motor was established in the Çerkezköy Organized Industrial Zone to expand their product line. The company operates on a 135,000 m<sup>2</sup> open area, with 70,000 m<sup>2</sup> of enclosed space, dedicated to the production of electric motors ranging from IEC 63 to 315 frame sizes.

Our product portfolio includes three-phase motors in the IEC 63 to 315 frame size range, single-phase motors in the IEC 63 to 90 frame size range (offering options with run or run + start capacitor), Zone 2/22 Exproof motors in the IEC 63 to 315 frame size, and Zone 1/21 Exproof motors in the IEC 100-280 frame size.

All motor series are designed in accordance with European standards and are available in IE2, IE3, and IE4 efficiency classes, ensuring they meet customer requirements. Moreover, our motors were initially designed to meet the IE3 efficiency class, enabling a seamless transition from IE2 to IE3 without altering the mechanical dimensions, providing users with consistent performance and compatibility.

In addition to our standard motors, we also offer custom-designed motors tailored to meet specific performance and compatibility needs of our customers.

Produced entirely at our Çerkezköy factory, ELK Motors undergo a comprehensive production process that includes engineering, machining, casting, sheet metal work, and motor winding. Each motor is subjected to 100% final inspection and testing to ensure the highest levels of quality and performance upon delivery.

Finally, ELK Motor adheres to strict quality management systems and holds the necessary product certifications to meet customer demands. Our quality system is certified to ISO 9001, and our products carry UL certification.



# CONTENTS

<b>THREE PHASE MOTORS</b>	6
Technical Information	6
IEC/EN/UL Compatibility	7
Electrical Construction	8
Electrical Connections	8
Motors at 60Hz Network	9
Operating Motors with Variable Speed Drives	9
Operating Motors in Various Environmental Conditions	9
Duty Cycle	10
Winding Insulation / Temperature Rise Classes	12
Protection Classes	12
Vibration Classes	13
Cooling Classes	14
Mechanical Construction	15
Construction Types	16
Bearings and Shaft Seals	18
Lubrication	19
Radial Loads	22
Axial Loads	24
Product Type Codes of Three-Phase Motors	28
<b>THREE-PHASE MOTORS</b>	29
IE2 Motors	29
IE3 Motors	31
IE4 Motors	36
Dimensions	40
Motor Nameplate Description	44
Three-Phase Motors Spare Parts	45
<b>SINGE-PHASE MOTORS</b>	46
Technical Information	46
Electrical Construction	47
Electrical Connections	47
Mechanical Construction	48
Bearings and Shaft Seals	48
Radial Loads	49
Axial Loads	49
Product Type Codes of Single-Phase Motors	51
<b>SINGLE-PHASE IE2 MOTORS</b>	52
IE2 Motors with Run Capacitor	53
IE2 Motors with Run + Start Capacitor	54
Dimensions	55
Motor Nameplate Description	58
Single-Phase Motors Spare Parts	59

# CONTENTS

<b>EXPROOF MOTORS</b>	61
Technical Information	61
Overview	62
IEC/EN/UL Compatibility	62
Explosion Protection Directive	63
Electrical Construction	64
Electrical Connections	64
Winding Insulation / Temperature Rise Classes	65
Protection Classes	65
Mechanical Construction	66
Bearings and Shaft Seals	68
Radial Loads	70
Axial Loads	72
Product Type Codes of Exproof Motors	75
<b>ZONE 2/22 EXPROOF MOTORS</b>	76
IE2 Motors	76
IE3 Motors	78
IE4 Motors	82
<b>ZONE 1/21 EXPROOF MOTORS</b>	86
IE3 Motors	86
IE4 Motors	89
Dimensions	91
Motor Nameplate Description	98
Motors Spare Parts	100
<b>ACCESSORIES AND COMPONENTS</b>	102
PTC Thermistor and Thermal Switch	103
Anti-Condensation Space Heater and Drainage	103
NDE Shaft and Canopy	103
Brake, Hand Release, Separately Driven Fan, Encoder and Backstop	104
<b>NOTES</b>	105

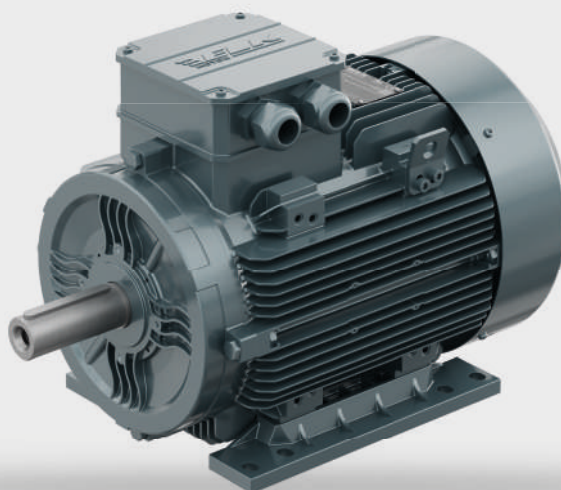

**THREE-PHASE MOTORS**



**Technical Information**

## IEC/EN/UL Compatibility

Our standard products are designed, manufactured, and tested in full compliance with the standards listed below.

IEC 60034-1	Rating and Performance
IEC 60034-2-1	Methods for Determining Losses and Efficiency
IEC 60034-5	Classification of Degrees of Protection
IEC 60034-6	Methods of Cooling
IEC 60034-7	Symbols of Construction and Mounting Arrangements
IEC 60034-8	Terminal Markings and Direction of Rotation
IEC 60034-9	Noise Limits
IEC 60034-11	Built-in Thermal Protection
IEC 60034-14	Vibration Limits
IEC 60034-18-1	Functional Evaluation of Insulation Systems
IEC 60034-30	Efficiency Classes (IE Code)
IEC 60038	Standard Voltages
EN 50347	Dimensions and Output Powers for Electrical Machines

EN 55014-1	Electromagnetic Compatibility
EN 61000-3-2	
EN 61000-3-3	

UL1004-1	Rotating Electrical Machines – General Requirements
CSA C22.2 No. 100	Motors and Generators



Labeled electric motors are all UL certified and manufactured in accordance with UL1004-1 and CSA C22.2 No. 100 standards under file number E496161.

Our products may deviate from the nominal values specified in our catalog by the amounts or percentages permitted under IEC 60034-1, as outlined below.

<b>Motor Speed (n)</b>	$\Delta n = \pm 20\% (n_s - n_N), P_N \geq 1 \text{ kW}$ $\Delta n = \pm 30\% (n_s - n_N), P_N < 1 \text{ kW}$
<b>Efficiency %(<math>\eta</math>)</b>	$\Delta \eta = -15\% (100 - \eta_N)$
<b>Power factor (<math>\varphi</math>)</b>	$\text{Cos } \varphi = -1/6 (1 - \text{Cos } \varphi)$
<b>Locked rotor current (<math>I_{L,N}</math>)</b>	$\Delta (I_{L,N}) = +20\% (I_{L,N})$
<b>Starting torque (<math>M_L/M_N</math>)</b>	min. $(M_L/M_N) = -15\% (M_L/M_N)$ max. $(M_L/M_N) = +25\% (M_L/M_N)$
<b>Breakdown torque (<math>M_K/M_N</math>)</b>	$(M_K/M_N) = -10\% (M_K/M_N)$
<b>Torque of inertia (J) [kgm<sup>2</sup>]</b>	$\Delta J = \pm 10\% J$
<b>Sound pressure level (<math>L_{PA}</math>) [dB(A)]</b>	$L_{PA} = +3 \text{ dB (A)}$

## Electrical Construction

Our standard motors have an F class (155°C) electrical insulation system. However, all standard motors in our product range operate within B class temperature rise limits. This ensures that the provided temperature class has a safety margin, allowing our motors to operate under more demanding conditions than specified or to have a longer service life under normal conditions. Motors with H class insulation can be manufactured according to customer requirements.

## Electrical Connections

Cable Gland and Blind Cap														
Frame Size	063	071	080	090	100	112	132	160	180	200	225	250	280	315
Cable Glands	M16x1,5	M20x1,5			M25x1,5			2 x M32x1,5		1 x M12x1,5 2 x M40x1,5	1 x M12x1,5 2 x M50x1,5	2 x M63x1,5		
Blind Cap	M16x1,5				M25x1,5			-	-	-	-			

Terminal Connections														
Frame Size	063	071	080	090	100	112	132	160	180	200	225	250	280	315
Terminal Size	M4				M5			M6			M8	M10		M16

The motors shall be connected in star or delta according to rated voltage given in their nameplate and the network voltage that they will be connected. For phase to phase 400V supply the motors with 230/400V nameplate values shall be connected in star and the motors with 400/690V nameplate values shall be connected in delta. Star-Delta starting is applicable to 400/690V motors when operated on a 400V supply network. The connection types given below should be applied for three phase motors, depending on the direction of rotation.

## Terminal Connections for Three-Phase Motors

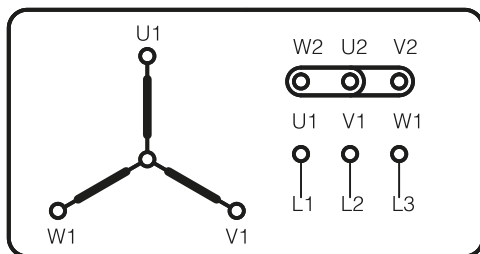

Y Star Connection  
Clockwise

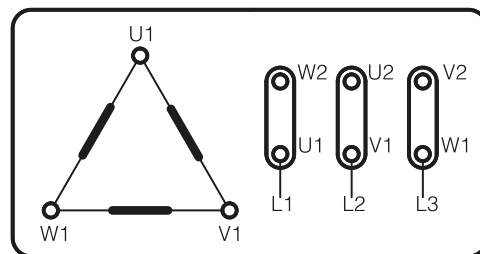

Δ Delta Connection  
Clockwise

Standard ELK Motors are manufactured to rotate in a clockwise direction. To change the rotation direction, the positions of any two phases on the terminal can be swapped. For an example, please refer to the schematic below.

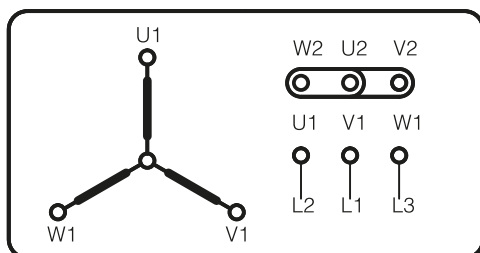

Y Star Connection  
Counter-Clockwise

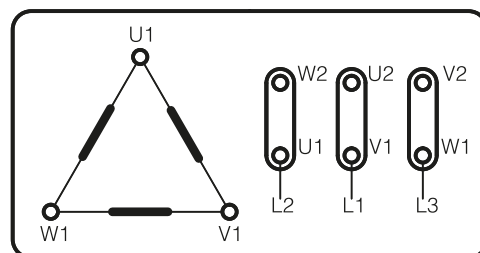

Δ Delta Connection  
Counter-Clockwise

## Motors at 60Hz Network

Standard ELK Motors that have been manufactured for 50 Hz power supply can be used at 60Hz network. The ratios given below indicate changes in the given rated values. It must be ensured that the pump, fan, or similar load driven by the motor does not overload it beyond its rated power due to speed variations caused by frequency changes. Appropriate adjustments must be made accordingly.

50 Hz Rated Voltage	60 Hz Rated Voltage	Rated Speed	Rated Power	Rated Torque	Rated Current	Starting Torque	Break down Torque	Starting Current
230V	220V	1.193	1	0.84	0.97	0.77	0.8	0.8
400V	380V	1.193	1	0.84	0.97	0.77	0.8	0.8
400V	440V	1.20	1.16	0.97	0.98	0.87	0.9	0.9

## Operating Motors with Variable Speed Drives

Standard ELK Motors are designed to be compatible with drives. When operated with an internal fan or a force cooling fan, the torque capacity of the motors is as shown in the frequency-torque curve below. An external force cooling fan must be used when operating at low speed for prolonged time. The power cables between the VSD and the motor should be kept as short as possible.

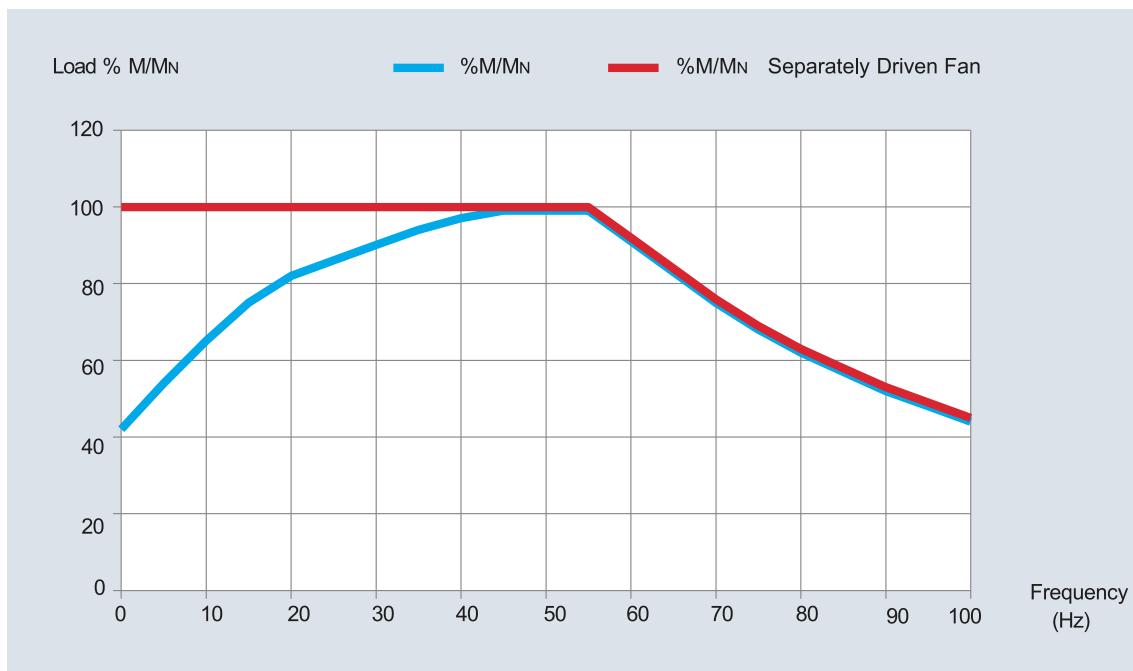

## Operating Motors in Various Environmental Conditions

The performance values of our motors specified in the catalogue are valid for use at an ambient temperature of 40°C and altitudes up to 1000 meters, as specified in IEC 60034-1. For other ambient temperatures, the output power of our motors will vary according to the ratios given in the table below.

Ambient Temperature	<30 °C	35 °C	40 °C	45 °C	50 °C	55 °C	60 °C
%Power Ratio	105	102	100	97	93	87	82

# Operating Motors in Various Environmental Conditions

Nominal Power Changes According to Altitude							
Altitude	Up to 1000 m	Up to 1500 m	Up to 2000 m	Up to 2500 m	Up to 3000 m	Up to 3500 m	Up to 4000 m
%Power Ratio	100	98	95	91	87	83	78

## Duty Cycle

Our standard motors have an S1 Duty Cycle, and the types of operation specified in IEC 60034-1 are listed below:

<b>S1</b>	<b>Continuous Duty</b>		<b>S2</b>	<b>Short-Time Duty</b>	
<p>The motor operates at a constant load long enough to reach thermal equilibrium</p>			<p>The motor runs at a constant load for a limited time, shorter than the time needed to reach thermal equilibrium, followed by a rest period. In general, 10, 30, 60, and 90-minute operating times are recommended.</p>		

<b>S3</b>	<b>Intermittent Periodic Duty</b>		<b>S4</b>	<b>Intermittent Periodic Duty with Starting</b>	
<p>The motor operates in a sequence of identical cycles, each consisting of a period of constant load and a rest period. The rest period is long enough to prevent the motor from reaching thermal equilibrium. The operating period duration is typically 10 minutes, with relative operating times of 15%, 25%, 40%, and 60%.</p>			<p>Similar to S3, but includes a significant starting period where the motor starts with a load, followed by a period of constant load and a rest period. In general, 10, 30, 60, and 90-minute operating times are recommended.</p>		

# Duty Cycle

<p><b>S5</b></p>	<p><b>Intermittent Periodic Duty with Electrical Braking</b></p>		<p><b>S6</b></p> <p><b>Continuous Operation Periodic Duty</b></p>	
<p>The motor operates in a sequence of identical duty cycles, each cycle consisting of a starting time, a time of operation at constant load, a time of electric braking and a time de-energized and at a rest.</p>		<p>The motor operates in a sequence of identical cycles, each consisting of a period of constant load followed by a period of no load. There is no rest period, so motor should be operated in such a way that it does not reach thermal equilibrium at full load. Typically, relative operating times of 15%, 25%, 40%, and 60% are used.</p>		

<p><b>S7</b></p>	<p><b>Continuous Operation Periodic Duty with Electrical Braking</b></p>		<p><b>S8</b></p> <p><b>Continuous Operation Periodic Duty with Load Variations</b></p>	
<p>This is a sequence of identical duty cycles, each consisting of a period of start, a period of operation at constant load and a period of electric braking. Operating periods are designed in a way that the motor does not reach thermal equilibrium. There is no rest and de-energizing periods.</p>		<p>This is a sequence of identical duty cycles, each consisting of a period of operation at constant load, corresponding to a determined speed of rotation, followed immediately by a period of operation at another load, corresponding to another speed of rotation. There is no rest and de-energizing period</p>		

<p><b>S9</b></p>	<p><b>Non-periodic Duty</b></p>	
<p>The motor operates under varying loads and speeds, which can be non-periodic. It includes overloads beyond the rated values.</p>		

# Winding Insulation / Temperature Rise Classes

All standard motors in the ELK Motor product range are equipped with a Class F (155°C) electrical insulation system. For motors with frame sizes 225 and above, a tropicalized varnish is applied as standard to improve the resistance of the windings against humidity, high temperatures, degradation, and acidic environments. Due to their superior design features, the temperature rise of all standard motors remains within the Class B limits under rated operating conditions. As a result of this temperature rise safety margin, our standard motors can deliver up to 15% more output power than their rated power, with a service factor of 1.15 (SF).

**INSULATION CLASS**

**Maximum Winding Temperature**

---

**Tolerance**

---

**Limits of Winding Temperature**

---

**Ambient Temperature**

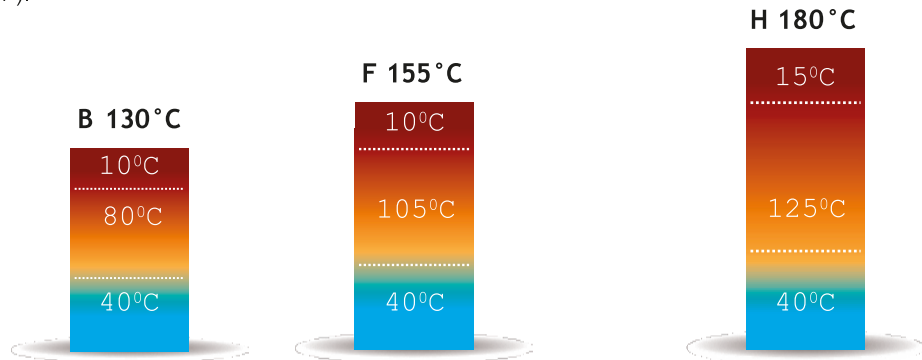

**B (Out of production)**  
Class B insulation system is shown for reference purposes only. Class B insulation system is not used in ELK motors

**F (Standard)**  
Our standard motors have an F-class electrical insulation system. The maximum permissible winding temperature at an ambient temperature of 40°C is 155°C.

**H (Optional)**  
H class insulation is provided on special request. At 40°C ambient temperature, the maximum permissible winding temperature is 180°C

## Protection Classes (IP)

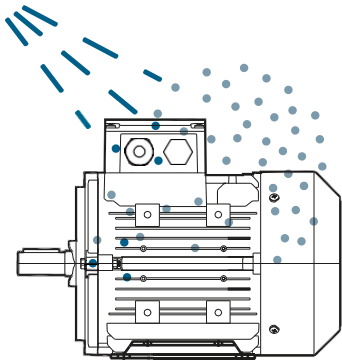

**IP55 (Standard)**  
Ingress of dust in amounts that could be harmful has been prevented, and ingress of water in amounts that could be harmful is prevented in case of water spray from any direction.

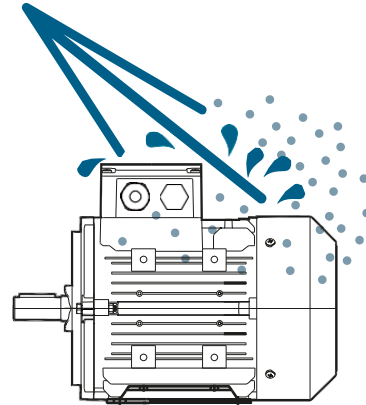

**IP56**  
Ingress of dust in amounts that could be harmful has been prevented, and ingress of water in amounts that could be harmful is prevented in case of pressurized water spray from any direction.

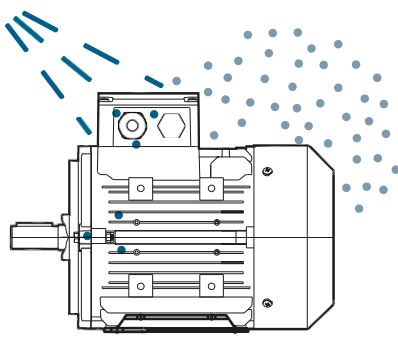

**IP65**  
Ingress of dust is completely prevented, and ingress of water in amounts that could be harmful is prevented in case of water spray from any direction.

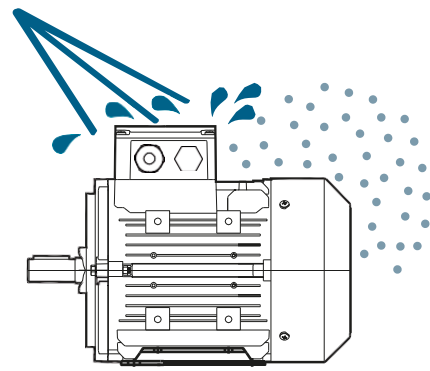

**IP66**  
Ingress of dust is completely prevented, and ingress of water in amounts that could be harmful is prevented in case of pressurized water spray from any direction..

## Protection Classes (IK)

It is the classification of the protection degrees provided by the motor's external enclosure against Mechanical / Physical impacts. ELK Motors provide standard protection with an IK08 rating.

Protection Class	Impact Energy (Joule)
IK00	No Protection
IK01	0,14
IK02	0,2
IK03	0,35
IK04	0,5
IK05	0,7
IK06	1
IK07	2
IK08	5 (ELK Motor Standard)
IK09	10
IK10	20

## Vibration Classes

In ELK motors, shaft balancing and vibration measurements are performed with a half key, and vibration levels are detected. Based on the IEC 60034-14 standard, we guarantee an A-class (free suspension) vibration level for our motors. The declared maximum vibration values are as shown in the table.

Vibration Grade	Shaft Height (mm)	56 ≤ H ≤ 132			132 < H ≤ 280			H > 280		
	Mounting	Displacement	Speed	Acceleration	Displacement	Speed	Acceleration	Displacement	Speed	Acceleration
		(μm)	(mm/s)	(m/s <sup>2</sup> )	(μm)	(mm/s)	(m/s <sup>2</sup> )	(μm)	(mm/s)	(m/s <sup>2</sup> )
A	Freely Suspended	25	1,6	2,5	35	2,2	3,5	45	2,8	4,4
	Rigidly Mounted	21	1,3	2	29	1,8	2,8	37	2,3	3,6
B	Freely Suspended	11	0,7	1,1	18	1,1	1,7	29	1,8	2,8
	Rigidly Mounted	-	-	-	14	0,9	1,4	24	1,5	2,4

## Cooling Classes

ELK Motors can be produced with the following cooling options in accordance with the IEC 60034-6 standard. Our standard motors are manufactured using the IC411 method.

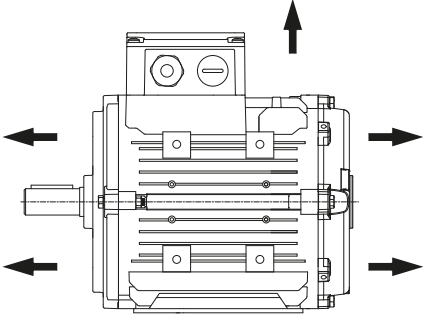
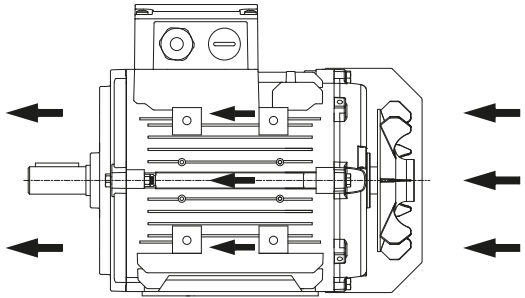
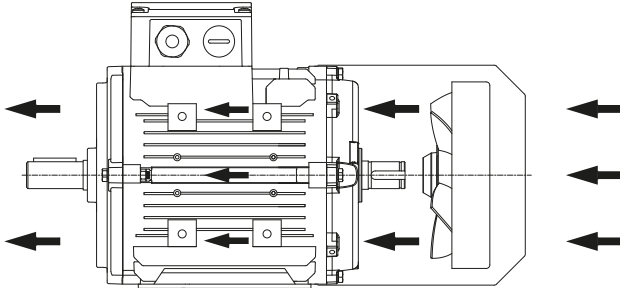
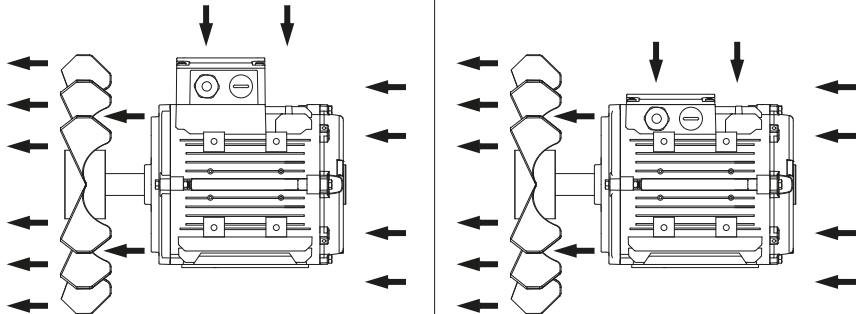
<p>IC410 - TENV</p>		
<p>IC411 - TEFC</p>		
<p>IC416 - TEBC</p>		
<p>IC418 - TEAO</p>		

# Mechanical Construction

ELK Motors feature a detachable foot structure in all frame sizes, on top of that, the foot can also be attached to three sides of the body. This allows users to easily configure the motor with the terminal box on the right, top, or left by changing the feet position. In standard motors, the terminal box is positioned on the top.

## MOTOR SIZE 63-315

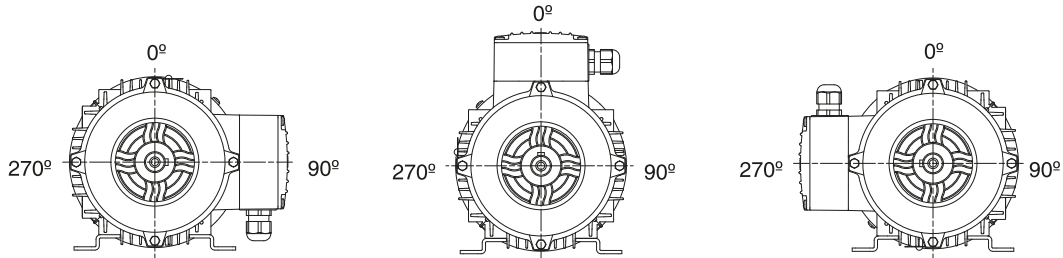

Additionally, due to the symmetric frame and foot structure of ELK Motors\*, the C dimension remains constant when the DE end-shield, NDE end-shield, and the shaft direction are changed. This allows the terminal box to be positioned closer to either the DE or NDE side (fan) side.

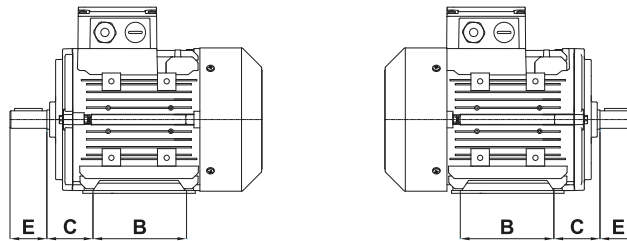

The materials used in our products are as specified below.

Frame Size	Housing	End Shield DE	End Shield NDE	Terminal Box & Cover	Feet	Fan Cover	Fan
63	Aluminum	Aluminum	Aluminum	Aluminum	Steel Sheet	Steel Sheet	Plastic
71	Aluminum	Aluminum	Aluminum	Aluminum	Steel Sheet	Steel Sheet	Plastic
80	Aluminum	Aluminum	Aluminum	Aluminum	Steel Sheet	Steel Sheet	Plastic
90	Aluminum	Aluminum	Aluminum	Aluminum	Steel Sheet	Steel Sheet	Plastic
100	Aluminum	Aluminum	Aluminum	Aluminum	Steel Sheet	Steel Sheet	Plastic
112	Aluminum	Aluminum	Aluminum	Aluminum	Steel Sheet	Steel Sheet	Plastic
132	Aluminum	Aluminum	Aluminum	Aluminum	Steel Sheet	Steel Sheet	Plastic
	Cast Iron	Cast Iron	Cast Iron	Cast Iron	Cast Iron	Steel Sheet	Plastic
160	Aluminum	Aluminum	Aluminum	Aluminum	Aluminum	Steel Sheet	Plastic
	Cast Iron	Cast Iron	Cast Iron	Cast Iron	Cast Iron	Steel Sheet	Plastic
180	Aluminum	Aluminum	Aluminum	Aluminum	Aluminum	Steel Sheet	Plastic
	Cast Iron	Cast Iron	Cast Iron	Cast Iron	Cast Iron	Steel Sheet	Plastic
200	Aluminum	Aluminum	Aluminum	Aluminum	Aluminum	Steel Sheet	Plastic
	Cast Iron	Cast Iron	Cast Iron	Cast Iron	Cast Iron	Steel Sheet	Plastic
225	Aluminum	Aluminum	Aluminum	Aluminum	Aluminum	Steel Sheet	Plastic
	Cast Iron	Cast Iron	Cast Iron	Cast Iron	Cast Iron	Steel Sheet	Plastic
250	Aluminum	Aluminum	Aluminum	Aluminum	Aluminum	Steel Sheet	Plastic
	Cast Iron	Cast Iron	Cast Iron	Cast Iron	Cast Iron	Steel Sheet	Plastic
280	Cast Iron	Cast Iron	Cast Iron	Cast Iron	Cast Iron	Steel Sheet	Plastic
315	Cast Iron	Cast Iron	Cast Iron	Cast Iron	Cast Iron	Steel Sheet	Plastic

\* Motors that do not have a symmetric frame structure are indicated in the electrical characteristics tables.

# Construction Types

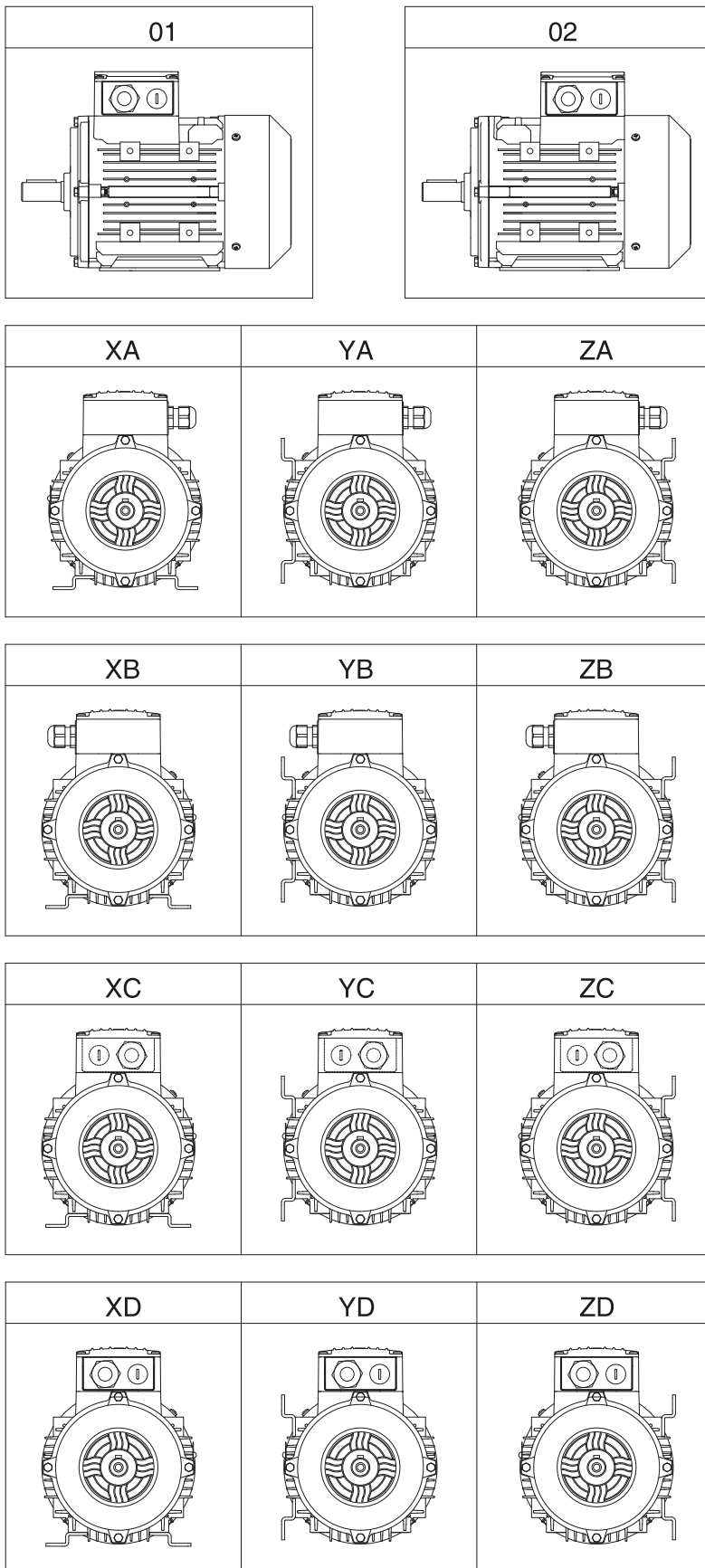

Standard ELK motors can be positioned with the terminal box on the drive side or the fan side. Depending on these options, the motor foot and flange orientation options are as shown in the table.

01: Terminal box on the drive side  
 02: Terminal box on the fan side



X: Feet on the ground when viewed from the drive side  
 Y: Feet on the left when viewed from the drive side  
 Z: Feet on the right when viewed from the drive side

A: Cable gland on the right when viewed from the drive side  
 B: Cable gland on the left when viewed from the drive side  
 C: Cable gland at the rear when viewed from the drive side  
 D: Cable gland at the front when viewed from the drive side

Optionally, if feet are not desired on the motor, mounting positions other than X, Y, and Z are available

# Construction Types

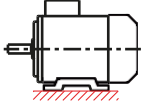
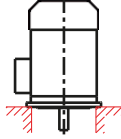
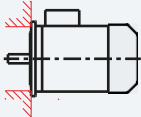
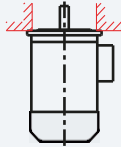
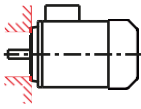
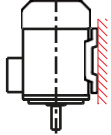
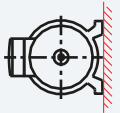
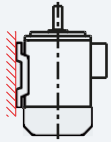
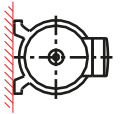
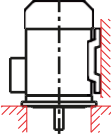
ELK motors are manufactured in accordance with International Mounting Standard IEC 60034-7.

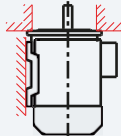
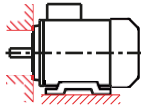
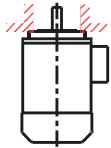
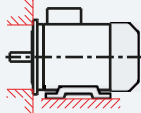
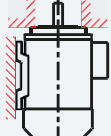
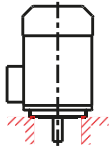
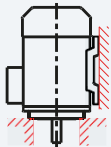
Mounting codes and diagrams according to IEC 60034-7					
Horizontal Mounting Codes			Vertical Mounting Codes		
	I	II		I	II
	IM B3	IM 1001		IM V1	IM 3011
	IM B5	IM 3001		IM V3	IM 3031
	IM B14	IM 3601		IM V5	IM 1011
	IM B7	IM 1061		IM V6	IM 1031
	IM B6	IM 1051		IM V15	IM 2011
	IM B8	IM 1071		IM V35	IM 2031
	IM B34	IM 2101		IM V19	IM 3631
	IM B35	IM 2001		IM V37	IM 2131
				IM V18	IM 3611
				IM V17	IM 2111

## Bearings

Standard ELK Motors are equipped with the ball bearings specified in the table, and optional NUP and NU type bearings can also be used.

Frame Size	Number of Poles	Drive End Bearing	Non-Drive End Bearing
63	2-4-6-8	6201 ZZ C3	6201 ZZ C3
71	2-4-6-8	6202 ZZ C3	6202 ZZ C3
80	2-4-6-8	6204 ZZ C3	6204 ZZ C3
90	2-4-6-8	6205 ZZ C3	6205 ZZ C3
100	2-4-6-8	6206 ZZ C3	6206 ZZ C3
112	2-4-6-8	6206 ZZ C3	6206 ZZ C3
132	2-4-6-8	6208 ZZ C3	6208 ZZ C3
160	2-4-6-8	6309 ZZ C3	6209 ZZ C3
180	2-4-6-8	6310 ZZ C3	6210 ZZ C3
200	2-4-6-8	6312 ZZ C3	6212 ZZ C3
225	2-4-6-8	6313 ZZ C3	6213 ZZ C3
250	2-4-6-8	6315 ZZ C3	6215 ZZ C3
280	2	6315 C3	6315 C3
	4-6-8	6317 C3	6317 C3
315	2	6316 C3	6316 C3
	4-6-8	6319 C3	6319 C3

## Bearing Sensors

Optional sensor applications are available in 250, 280, and 315 frame motors to measure the bearing temperature (PT100) and vibration (SPM) values.

## Shaft Seals

The shaft seals specified in the table are used in standard ELK Motors.

Frame Size	Number of Poles	Drive End Shaft Seal	Non-Drive End Shaft Seal
63	2-4-6-8	Ø12xØ24x4	Ø12xØ24x4
71	2-4-6-8	Ø15xØ30x4	Ø15xØ30x4
80	2-4-6-8	Ø20xØ30x4	Ø20xØ30x4
90	2-4-6-8	Ø25xØ35x4	Ø25xØ35x4
100	2-4-6-8	Ø30xØ40x4	Ø30xØ40x4
112	2-4-6-8	Ø30xØ40x4	Ø30xØ40x4
132	2-4-6-8	Ø40xØ52x4	Ø40xØ52x4
160	2-4-6-8	Ø45xØ72x7	Ø45xØ72x7
180	2-4-6-8	Ø50xØ72x8	Ø50xØ72x8
200	2-4-6-8	Ø60xØ90x10	Ø60xØ90x10
225	2-4-6-8	Ø65xØ80x10	Ø65xØ80x10
250	2-4-6-8	Ø75xØ90x10	Ø75xØ90x10
280	2	Ø75xØ115x10	Ø75xØ115x10
	4-6-8	Ø85xØ105x10	Ø85xØ105x10
315	2	Ø80xØ105x12	Ø80xØ105x12
	4-6-8	Ø95xØ120x10	Ø95xØ120x10

## Lubrication

In open bearing applications, axial and radial loads, along with temperature and motor speed factors, affect the lubrication intervals and quantities. The lubrication intervals and quantities are theoretically calculated and specified based on the permissible maximum radial and axial Loads given in the catalog, considering temperature and speed factors. In open bearing lubrication applications, it is important to use the type and brand of grease specified by the manufacturer. ELK Motors uses MOBIL Polyrex EM for open lubrication applications. The lubrication intervals for the relevant bearings are also indicated on the motor nameplate.

### 50 Hz Deep Groove Ball Bearing Lubrication Intervals

Frame	Pole	45 °C < T ≤ 65 °C				65 °C < T ≤ 80 °C				80 °C < T ≤ 95 °C			
		DE		NDE		DE		NDE		DE		NDE	
		Amount [g]	Time [h]	Amount [g]	Time [h]	Amount [g]	Time [h]	Amount [g]	Time [h]	Amount [g]	Time [h]	Amount [g]	Time [h]
132	2	7	11000	7	11000	7	5500	7	5500	7	2700	7	2700
	4	7	13000	7	18000	7	6300	7	9000	7	3200	7	4500
	6	7	15000	7	21000	7	7500	7	11000	7	3700	7	5400
160	2	13	8800	8	10000	13	4400	8	5000	13	2200	13	2500
	4	13	11000	8	17000	13	5700	8	8700	13	2800	13	4300
	6	13	14000	8	21000	13	7000	8	10000	13	3500	13	5200
180	2	15	7800	9	9200	15	3900	9	4600	15	1900	15	2300
	4	15	11000	9	17000	15	5300	9	8300	15	2700	15	4200
	6	15	13000	9	20000	15	6700	9	10000	15	3300	15	5100
200	2	20	6000	12	7200	20	3000	12	3600	20	1500	12	1800
	4	20	9400	12	15000	20	4700	12	7300	20	2400	12	3700
	6	20	12000	12	19000	20	6200	12	9300	20	3100	12	4700
225	2	23	5300	14	6300	23	2700	14	3200	23	1300	14	1600
	4	23	8900	14	14000	23	4400	14	6900	23	2200	14	3400
	6	23	12000	14	18000	23	5900	14	8900	23	3000	14	4500
250	2	30	4100	16	5300	30	2100	16	2700	30	1000	16	1300
	4	30	7800	16	13000	30	3900	16	6300	30	1900	16	3200
	6	30	11000	16	17000	30	5400	16	8400	30	2700	16	4200
280	2	30	4100	30	4100	30	2100	30	2100	30	1000	30	1000
	4	37	6900	37	9800	37	3400	37	4900	37	1700	37	2500
	6	37	10000	37	14000	37	5000	37	7100	37	2500	37	3600
315	2	33	3600	33	3600	33	1800	33	1800	33	910	33	910
	4	45	6100	45	8700	45	3000	45	4300	45	1500	45	2200
	6	45	9200	45	13000	45	4600	45	6500	45	2300	45	3300

\* The "T" value specified in the table is the bearing temperature.

## 60 Hz Deep Groove Ball Bearing Lubrication Intervals

Frame	Pole	45°C < T ≤ 65°C				65°C < T ≤ 80°C				80°C < T ≤ 95°C			
		DE		NDE		DE		NDE		DE		NDE	
		Amount [g]	Time [h]	Amount [g]	Time [h]	Amount [g]	Time [h]	Amount [g]	Time [h]	Amount [g]	Time [h]	Amount [g]	Time [h]
132	2	7	8900	7	8900	7	4500	7	4500	7	2200	7	2200
	4	7	11000	7	16000	7	5700	7	8200	7	2900	7	4100
	6	7	14000	7	20000	7	7000	7	10000	7	3500	7	5000
160	2	13	6900	8	8100	13	3500	8	4000	13	1700	8	2000
	4	13	10000	8	16000	13	5000	8	7800	13	2500	8	3900
	6	13	13000	8	19000	13	6400	8	9700	13	3200	8	4800
180	2	15	5900	9	7300	15	3000	9	3600	15	1500	9	1800
	4	15	9300	9	15000	15	4700	9	7400	15	2300	9	3700
	6	15	12000	9	19000	15	6100	9	9400	15	3100	9	4700
200	2	20	4400	12	5400	20	2200	12	2700	20	1100	12	1300
	4	20	8000	12	13000	20	4000	12	6300	20	2000	12	3200
	6	20	11000	12	17000	20	5500	12	8500	20	2800	12	4200
225	2	23	3800	14	4600	23	1900	14	2300	23	940	14	1200
	4	23	7400	14	12000	23	3700	14	5900	23	1900	14	2900
	6	23	11000	14	16000	23	5300	14	8000	23	2600	14	4000
250	2	30	2800	16	3800	30	1400	16	1900	30	700	16	940
	4	30	6400	16	11000	30	3200	16	5300	30	1600	16	2700
	6	30	9500	16	15000	30	4800	16	7500	30	2400	16	3800
280	2	30	2800	30	2800	30	1400	30	1400	30	700	30	700
	4	37	5500	37	7900	37	2700	37	3900	37	1400	37	2000
	6	37	8600	37	12000	37	4300	37	6100	37	2100	37	3100
315	2	33	2400	33	2400	33	1200	33	1200	33	600	33	600
	4	45	4700	45	6700	45	2400	45	3400	45	1200	45	1700
	6	45	7800	45	11000	45	3900	45	5500	45	1900	45	2800

\* The "T" value specified in the table is the bearing temperature.

## 50 Hz Cylindrical Roller Bearing Lubrication Intervals

Frame	Pole	45°C < T ≤ 65°C		65°C < T ≤ 80°C		80°C < T ≤ 95°C	
		DE		DE		DE	
		Amount [g]	Time [h]	Amount [g]	Time [h]	Amount [g]	Time [h]
132	2	10	2000	10	1000	10	510
	4	10	4600	10	2300	10	1200
	6	10	6100	10	3000	10	1500
160	2	13	1700	13	840	13	420
	4	13	4200	13	2100	13	1000
	6	13	5700	13	2800	13	1400
180	2	15	1400	15	700	15	350
	4	15	3800	15	1900	15	1000
	6	15	5300	15	2700	15	1300
200	2	20	950	20	480	20	240
	4	20	3200	20	1600	20	800
	6	20	4700	20	2400	20	1200
225	2	23	800	23	400	23	200
	4	23	3000	23	1500	23	750
	6	23	4400	23	2200	23	1100
250	2	30	540	30	270	30	130
	4	30	2400	30	1200	30	600
	6	30	4000	30	2000	30	1000
280	2	30	540	30	270	30	130
	4	30	2400	30	1200	30	600
	6	30	3900	30	1900	30	970
315	2	33	440	33	220	33	110
	4	33	2200	33	1100	33	540
	6	33	3700	33	1800	33	920

\* The "T" value specified in the table is the bearing temperature.

### Bearing Lubrication Schematic

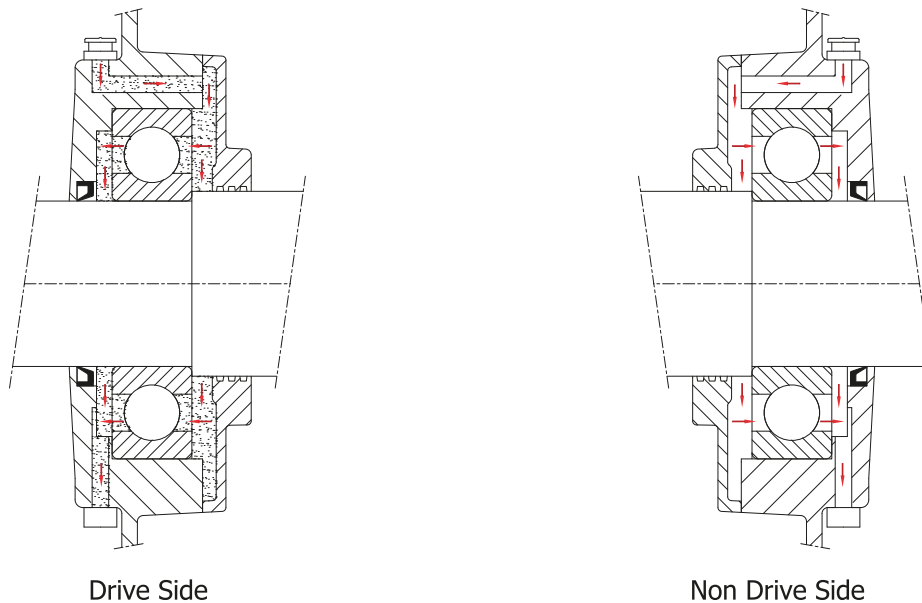

## Radial Loads

Radial Load on the Shaft (FR):

The radial load can be calculated using the following formula.

The calculated radial load should not exceed the permissible values specified in the tables ( $FR < Fr_x$ ).

If it does, please consult us.

$$F_R = k \cdot \frac{P}{D \cdot n} \cdot 10^7 \text{ (N)}$$

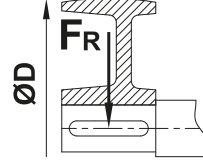

Correction of Permissible Radial Load ( $Fr_x$ ):

If the radial load acting on the shaft is between the  $x_0$  and  $x_{max}$  values, the permissible value should be corrected using the following formula.

$$Fr_x = Fr_0 - \frac{x}{E} (Fr_0 - Fr_{max})$$

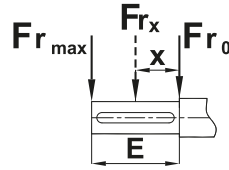

P: Motor Power (kW)

D: Shaft Diameter (mm)

n: Motor Speed (rpm)

k: Radial Load Factor

- Spur Gears, chain drives with low speed = 2.1
- Trigger Belts = 2,5
- V type belts = 5

$FR < Fr_x$  : The radial load on the shaft must be less than the permissible maximum radial load.

Fa: Axial load acting on the shaft.

Fr0: Permissible maximum radial load on the shaft.

Fr max: Permissible maximum radial load at the end of the shaft.

Permissible load calculations are based on a bearing life of Lh10 20,000 hours according to ISO 281.

# Radial Loads

HORIZONTAL MOUNTING - Permissible Radial Loads  
 Mounting Positions IM: B3, B5, B6, B7, B8, B14, B34, B35

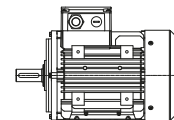

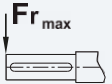
Frame Size	Fa = 0	
		
<b>2 Poles 3000 rpm</b>	<b>Fr<sub>0</sub> [N]</b>	<b>Fr<sub>max</sub> [N]</b>
63	380	330
71	430	360
80	720	580
90	790	660
100	1100	900
112	1100	900
132	1600	1270
160	2950	2300
180	3500	2850
200	4500	3700
225	5100	4100
250	6150	5100
280	6700	5100
315	6300	5550
<b>4 Poles 1500 rpm</b>	<b>Fr<sub>0</sub> [N]</b>	<b>Fr<sub>max</sub> [N]</b>
63	490	420
71	550	470
80	900	730
90	1000	830
100	1400	1110
112	1400	1140
132	2000	1600
160	3650	2850
180	4300	3500
200	5600	4600
225	6300	5100
250	7800	6300
280	9400	7700
315	9900	8200
<b>6 Poles 1000 rpm</b>	<b>Fr<sub>0</sub> [N]</b>	<b>Fr<sub>max</sub> [N]</b>
71	630	520
80	1020	850
90	1150	930
100	1600	1250
112	1600	1300
132	2300	1850
160	4200	3250
180	5000	4000
200	6450	5450
225	7350	5800
250	8950	7300
280	10500	8800
315	11000	9300

Fa0 : Permissible maximum axial load

Fr : Radial force acting on the shaft

Fr0 : Permissible maximum radial load at the end of the shaft

Fr max : Permissible maximum radial load at the shaft end

Permissible load calculations are based on a bearing life of Lh10 20,000 hours according to ISO 281.

# Axial Loads

HORIZONTAL MOUNTING - Permissible Axial Loads  
 Mounting Positions IM: B3, B5, B6, B7, B8, B14, B34, B35

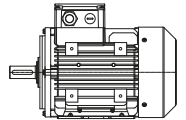

Frame Size	Push			Pull
	Fr = 0	Fr = Fr <sub>0</sub>	Fr = Fr <sub>max</sub>	Fr = 0
<b>2 Poles 3000 rpm</b>	<b>Fa<sub>0</sub> [N]</b>	<b>Fa<sub>0</sub> [N]</b>	<b>Fa<sub>0</sub> [N]</b>	<b>Fa<sub>0</sub> [N]</b>
63	90	90	90	235
71	110	110	110	240
80	190	190	190	400
90	170	170	170	450
100	270	270	270	500
112	270	270	270	500
132	380	380	370	850
160	2400	1050	1050	1670
180	2700	1200	1150	2000
200	3200	1300	1200	2830
225	3700	1500	1500	3200
250	4150	1700	1600	3850
280	4500	1600	2500	3200
315	5200	2700	2700	3200
<b>4 Poles 1500 rpm</b>	<b>Fa<sub>0</sub> [N]</b>	<b>Fa<sub>0</sub> [N]</b>	<b>Fa<sub>0</sub> [N]</b>	<b>Fa<sub>0</sub> [N]</b>
63	90	90	90	330
71	110	110	110	360
80	190	190	190	560
90	170	170	210	645
100	300	300	300	800
112	300	300	300	800
132	400	400	400	1200
160	3100	1300	1350	2400
180	3500	1550	1400	2800
200	4400	1700	1650	4000
225	4950	1980	1900	4300
250	5700	2100	2200	5500
280	7300	3000	3000	5500
315	7800	3800	3700	5800
<b>6 Poles 1000 rpm</b>	<b>Fa<sub>0</sub> [N]</b>	<b>Fa<sub>0</sub> [N]</b>	<b>Fa<sub>0</sub> [N]</b>	<b>Fa<sub>0</sub> [N]</b>
71	110	110	110	430
80	190	190	190	700
90	170	170	170	780
100	290	290	290	950
112	290	290	290	980
132	380	380	380	1500
160	3600	1600	1600	2900
180	4100	1700	1700	3400
200	5050	2000	1980	4700
225	5800	2250	2200	5200
250	6700	2600	2700	6500
280	8500	3700	3700	6700
315	8900	4200	3900	6900

Fa<sub>0</sub> : Permissible maximum axial load

Fr : Radial force acting on the shaft

Fr<sub>0</sub> : Permissible maximum radial load at the end of the shaft

Fr<sub>max</sub> : Permissible maximum radial load at the shaft end

Permissible load calculations are based on a bearing life of L<sub>h10</sub> 20,000 hours according to ISO 281.

# Axial Loads

VERTICAL MOUNTING - Shaft Pointing Upwards - Permissible Axial Loads  
 Mounting Positions IM: V3, V6, V19, V35, V37

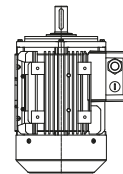

Frame Size	Push			Pull
	Fr = 0	Fr = Fr <sub>0</sub>	Fr = Fr <sub>max</sub>	Fr = 0
<b>2 Poles 3000 rpm</b>	<b>Fa<sub>0</sub> [N]</b>	<b>Fa<sub>0</sub> [N]</b>	<b>Fa<sub>0</sub> [N]</b>	<b>Fa<sub>0</sub> [N]</b>
63	90	90	90	240
71	100	100	100	265
80	170	170	170	440
90	130	130	180	480
100	250	250	250	600
112	250	250	250	660
132	300	300	300	1050
160	2200	850	850	2000
180	2450	900	800	2500
200	2900	850	850	3700
225	3200	900	800	4100
250	3600	950	850	5200
280	4100	1200	1500	4700
315	3500	850	800	6500
<b>4 Poles 1500 rpm</b>	<b>Fa<sub>0</sub> [N]</b>	<b>Fa<sub>0</sub> [N]</b>	<b>Fa<sub>0</sub> [N]</b>	<b>Fa<sub>0</sub> [N]</b>
63	90	90	90	345
71	95	95	95	380
80	160	160	160	600
90	120	110	110	700
100	210	210	210	900
112	210	210	210	950
132	240	240	240	1550
160	2800	1050	1050	2820
180	3150	1100	1100	3450
200	3750	1150	1150	4800
225	4300	1200	1200	5600
250	4900	1200	1200	7000
280	6500	2250	2250	7100
315	5000	500	700	11000
<b>6 Poles 1000 rpm</b>	<b>Fa<sub>0</sub> [N]</b>	<b>Fa<sub>0</sub> [N]</b>	<b>Fa<sub>0</sub> [N]</b>	<b>Fa<sub>0</sub> [N]</b>
71	95	95	95	455
80	160	160	160	745
90	115	115	120	850
100	230	230	230	1120
112	210	210	210	1100
132	250	250	250	1750
160	3350	1300	1300	3300
180	3750	1400	1430	4000
200	4500	1500	1350	5600
225	4800	1550	1500	6500
250	5800	1600	1500	8000
280	7000	2200	2100	9000
315	6400	1050	1050	13300

Fa<sub>0</sub> : Permissible maximum axial load

Fr : Radial force acting on the shaft

Fr<sub>0</sub> : Permissible maximum radial load at the end of the shaft

Fr<sub>max</sub> : Permissible maximum radial load at the shaft end

Permissible load calculations are based on a bearing life of L<sub>h10</sub> 20,000 hours according to ISO 281.

# Axial Loads

VERTICAL MOUNTING – Shaft Pointing Downwards - Permissible Axial Loads  
 Mounting Positions IM: V1, V5, V15, V17, V18

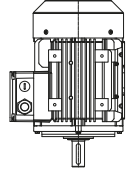

Frame Size	Push			Pull
	Fr = 0	Fr = Fr <sub>0</sub>	Fr = Fr <sub>max</sub>	Fr = 0
<b>2 Poles 3000 rpm</b>	<b>Fa<sub>0</sub> [N]</b>	<b>Fa<sub>0</sub> [N]</b>	<b>Fa<sub>0</sub> [N]</b>	<b>Fa<sub>0</sub> [N]</b>
63	110	110	110	230
71	130	130	130	235
80	220	220	220	385
90	220	220	250	420
100	400	330	330	490
112	550	340	340	440
132	490	550	550	680
160	2720	1410	1410	1500
180	3200	1650	1650	1700
200	4000	2000	2000	2450
225	4600	2300	2400	2630
250	5500	2700	2750	3300
280	6500	3500	3900	2250
315	8500	6100	6100	1500
<b>4 Poles 1500 rpm</b>	<b>Fa<sub>0</sub> [N]</b>	<b>Fa<sub>0</sub> [N]</b>	<b>Fa<sub>0</sub> [N]</b>	<b>Fa<sub>0</sub> [N]</b>
63	120	110	120	320
71	130	130	130	340
80	220	220	220	540
90	230	230	230	580
100	380	370	380	700
112	410	400	400	700
132	580	700	570	1040
160	3550	1800	1800	2100
180	4200	2100	2200	2450
200	5200	2600	2640	3350
225	6100	3100	3250	3740
250	7500	3800	4000	4440
280	8900	4750	4850	4600
315	13000	9100	8800	3000
<b>6 Poles 1000 rpm</b>	<b>Fa<sub>0</sub> [N]</b>	<b>Fa<sub>0</sub> [N]</b>	<b>Fa<sub>0</sub> [N]</b>	<b>Fa<sub>0</sub> [N]</b>
71	130	130	130	400
80	220	220	220	675
90	230	230	230	730
100	360	360	360	850
112	390	390	390	830
132	560	560	560	1350
160	4050	2000	2000	2650
180	4700	2300	2300	3050
200	5900	2800	2750	4150
225	7000	3550	3600	4500
250	8200	4050	4000	5500
280	10800	6000	6000	5050
315	15000	10000	10000	4300

Fa<sub>0</sub> : Permissible maximum axial load

Fr : Radial force acting on the shaft

Fr<sub>0</sub> : Permissible maximum radial load at the end of the shaft

Fr<sub>max</sub> : Permissible maximum radial load at the shaft end

Permissible load calculations are based on a bearing life of Lh10 20,000 hours according to ISO 281.

# Radial Loads (NUP)

HORIZONTAL MOUNTING - Permissible Radial Loads  
 Mounting Positions IM: B3, B5, B6, B7, B8, B14, B34, B35

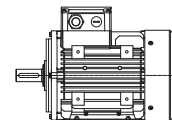

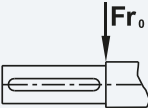
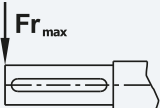
Frame Size	Fa = 0	
		
<b>2 Poles 3000 rpm</b>	<b>Fr<sub>0</sub> [N]</b>	<b>Fr<sub>max</sub> [N]</b>
132	6800	5200
160	8200	4500
180	9500	7300
200	12700	10400
225	15500	11300
250	20500	13600
280	20500	17000
315	22000	18500
<b>4 Poles 1500 rpm</b>	<b>Fr<sub>0</sub> [N]</b>	<b>Fr<sub>max</sub> [N]</b>
132	8500	6500
160	10000	6300
180	11500	9300
200	15500	12800
225	19000	14500
250	25000	17500
280	31000	26000
315	35000	30000
<b>6 Poles 1000 rpm</b>	<b>Fr<sub>0</sub> [N]</b>	<b>Fr<sub>max</sub> [N]</b>
132	9500	7600
160	11500	7100
180	13000	10500
200	17500	14500
225	21500	16500
250	28500	19500
280	35000	29000
315	40000	34000

Fa0 : Permissible maximum axial load

Fr : Radial force acting on the shaft

Fr0 : Permissible maximum radial load at the end of the shaft

Fr max : Permissible maximum radial load at the shaft end

Permissible load calculations are based on a bearing life of Lh10 20,000 hours according to ISO 281.

# Product Type Codes of Three-Phase Motors

**4**    **EL**    **160**    **M**    **4**    **E**    **PD**    **BA**    **000**

4	----->	<p>Motor Efficiency Classes:                  2: IE2                  3: IE3                  4: IE4</p>
EL	----->	<p>Basic Motor Type                  EL : Aluminum housing standard three-phase motors                  EG : Cast iron housing standard three-phase motors                  EC : Aluminum housing three-phase compact motors                  ED : Cast iron housing three-phase compact motors</p>
160	----->	<p>Frame Size: 63, 71, 80, 90, 100, 112, 132, 160, 180, 200, 225, 250, 280, 315                  Height of the shaft axis from feet base of motor (mm)</p>
M	----->	<p>Housing Length                  S : Short                  M: Medium                  L : Long</p>
4	----->	<p>Number of Poles                  2: 2 Poles 3000 rpm                  4: 4 Poles 1500 rpm                  6: 6 Poles 1000 rpm                  8: 8 Poles 750 rpm</p>
E	----->	<p>Core Length: A, B, C, D, E, F, G</p>
PD	----->	<p>Construction Types Flange Types                  PD : B3 Foot Mounted                  FA : B5 Flange                  FB : B14/2 Flange                  PB : B14/2 Feet                  FC : B14 Flange                  FS : Special Flange                  PA : B35                  PC : B34                  PS : Foot mounted with special flange                  Y0..Y9 : With flange for gearbox connection                  PX : Foot mounted without drive end shield                  XX : Without foot and drive end shield                  Z0-Z9 : Foot mounted Yilmaz type</p>
BA	----->	<p>Electrical Specifications                  AA..ZZ Voltage, Frequency and electrical features</p> <p>1st digit : Voltage and Frequency                  A : 230/400V 50Hz                  B : 400/690V 50Hz                  C : 240/415V 50Hz                  D : 415/720V 50Hz                  E : 230/400V 60Hz                  F : 400/690V 60Hz                  G : 220V 60Hz                  H : 290/500V 50Hz                  I : 220/380V 60Hz                  J : 380/660V 60Hz</p> <p>2nd digit : Additional electrical features                  0: Standard motor, basic version                  A: Motors with thermistor                  B: Motors with anti-condensation heater                  C: Motors with thermal switch                  D: Motors with PT100 Temperature sensor                  J: Motors with PT1000 Temperature sensor                  K: Motors with thermistor and anti-condensation heater</p>
000	----->	<p>Additional Motor Features                  000 : Standard Motor</p>

**THREE-PHASE MOTORS**



**IE2**

**Motors**

# Electrical Characteristics

400V 50Hz 3000 rpm

Duty Cycle : S1 (Continuous Operation)  
 Insulation Class : F (155°C)  
 Temperature Raise : B (80°K)



Voltage (V)	Type	Rated Values								Starting Values		Break Down Torque	Moment of Inertia	B3 Motor Weight	Sound Pressure Level
		Power	Speed	Current	Torque	Power Factor	Efficiency % $\eta$			Current	Torque				
		kW	rpm	A	Nm	Cos $\phi$	4/4	3/4	1/2	I <sub>A</sub> /I <sub>N</sub>	M <sub>A</sub> /M <sub>N</sub>				
230/400	2EL063M2A	0,18	2800	0,50	0,61	0,77	67,5	66,0	62,0	4,5	2,9	3,0	0,00012	3,80	51
	2EL063M2B	0,25	2800	0,67	0,85	0,78	69,0	68,0	63,5	4,5	2,9	3,0	0,00015	4,00	51
	2EL071M2A	0,37	2790	0,90	1,26	0,80	74,2	74,5	72,5	5,0	2,5	2,8	0,00031	5,70	54
	2EL071M2B	0,55	2790	1,27	1,88	0,82	75,8	77,0	76,0	5,0	2,8	2,9	0,00037	6,20	54

Our UL approved motors have the logo on their nameplates.

400V 50Hz 1500 rpm

Duty Cycle : S1 (Continuous Operation)  
 Insulation Class : F (155°C)  
 Temperature Raise : B (80°K)



Voltage (V)	Type	Rated Values								Starting Values		Break Down Torque	Moment of Inertia	B3 Motor Weight	Sound Pressure Level
		Power	Speed	Current	Torque	Power Factor	Efficiency % $\eta$			Current	Torque				
		kW	rpm	A	Nm	Cos $\phi$	4/4	3/4	1/2	I <sub>A</sub> /I <sub>N</sub>	M <sub>A</sub> /M <sub>N</sub>				
230/400	2EL063M4B	0,12	1400	0,42	0,82	0,70	60,1	60,5	54,5	3,0	2,1	2,3	0,00018	4,00	42
	2EL063M4C	0,18	1400	0,56	1,23	0,71	64,7	65,8	61,5	3,0	2,1	2,3	0,00022	4,40	42
	2EL071M4B	0,25	1425	0,71	1,68	0,69	74,0	73,5	70,5	4,4	2,0	3,0	0,00067	6,30	46
	2EL071M4C	0,37	1425	1,00	2,47	0,70	76,1	75,5	71,5	4,6	2,0	3,0	0,00082	7,00	46
	2EL080M4B	0,55	1440	1,45	3,65	0,71	77,1	76,7	75,0	5,2	2,0	3,0	0,00175	9,70	50

Our UL approved motors have the logo on their nameplates.

400V 50Hz 1000 rpm

Duty Cycle : S1 (Continuous Operation)  
 Insulation Class : F (155°C)  
 Temperature Raise : B (80°K)



Voltage (V)	Type	Rated Values								Starting Values		Break Down Torque	Moment of Inertia	B3 Motor Weight	Sound Pressure Level
		Power	Speed	Current	Torque	Power Factor	Efficiency % $\eta$			Current	Torque				
		kW	rpm	A	Nm	Cos $\phi$	4/4	3/4	1/2	I <sub>A</sub> /I <sub>N</sub>	M <sub>A</sub> /M <sub>N</sub>				
230/400	2EL071M6B	0,18	920	0,60	1,87	0,67	64,5	63,0	57,0	3,2	1,9	2,3	0,00076	6,10	42
	2EL071M6C	0,25	920	0,78	2,59	0,69	66,5	66,0	61,0	3,3	1,9	2,3	0,00096	6,70	42
	2EL080M6A	0,37	925	1,08	3,82	0,69	71,4	71,5	70,0	4,0	2,0	2,6	0,00176	9,10	45
	2EL080M6B	0,55	932	1,50	5,64	0,72	73,5	74,0	71,0	4,2	2,1	2,6	0,00202	9,80	45

Our UL approved motors have the logo on their nameplates.



**THREE-PHASE MOTORS**



**IE3**

**Motors**

# Electrical Characteristics

400V 50Hz 3000 rpm

Duty Cycle : S1 (Continuous Operation)  
 Insulation Class : F (155°C)  
 Temperature Raise : B (80°K)



Voltage (V)	Type	Rated Values								Starting Values		Break Down Torque	Moment of Inertia	B3 Motor Weight	Sound Pressure Level
		Power	Speed	Current	Torque	Power Factor	Efficiency % $\eta$			Current	Torque				
		kW	rpm	A	Nm	Cos $\phi$	4/4	3/4	1/2	I <sub>A</sub> /I <sub>N</sub>	M <sub>A</sub> /M <sub>N</sub>				
230/400	3EL063M2A	0,18	2805	0,48	0,61	0,77	70,0	68,5	62,8	4,5	3,0	3,1	0,00012	4,00	51
	3EL063M2B	0,25	2805	0,65	0,85	0,79	71,0	69,7	64,2	4,6	3,0	3,1	0,00015	4,20	51
	3EL071M2B	0,37	2830	0,84	1,25	0,82	76,6	77,0	75,0	6,0	2,8	3,0	0,00037	6,30	53
	3EL071M2C	0,55	2830	1,19	1,86	0,84	79,4	80,2	78,8	6,1	2,9	3,3	0,00046	7,00	53
	3EL080M2B	0,75	2880	1,59	2,49	0,84	80,7	82,0	81,5	6,7	3,0	3,6	0,00103	9,60	54
	3EL080M2C	1,10	2880	2,26	3,64	0,85	82,7	83,0	82,4	6,8	3,1	3,8	0,00124	10,9	54
	3EL090S2B	1,50	2900	2,97	4,94	0,86	84,8	85,4	84,2	7,6	3,1	3,9	0,00178	15,2	59
	3EL090L2C	2,20	2900	4,25	7,24	0,87	85,9	86,8	86,1	7,2	3,0	3,8	0,00221	17,5	59
3EL100L2C	3,00	2910	5,58	9,85	0,89	87,1	87,6	86,9	7,9	3,0	4,1	0,00450	23,8	62	
400/690	3EL112M2C	4,00	2915	7,28	13,1	0,90	88,1	88,8	88,2	7,5	2,6	3,9	0,00618	29,4	65
	3EL132S2B	5,50	2945	9,90	17,8	0,90	89,2	89,0	88,6	8,9	2,9	3,9	0,01732	45,7	67
	3EL132S2C	7,50	2945	13,2	24,3	0,91	90,1	90,5	89,7	8,4	2,6	4,0	0,02104	52,0	67
	3EL160M2B	11,0	2950	19,7	35,6	0,88	91,2	91,0	90,5	8,5	2,6	3,9	0,03318	79,7	69
	3EL160M2C	15,0	2950	26,5	48,6	0,89	91,9	92,1	91,6	8,9	3,1	4,2	0,03913	87,8	69
	3EL160L2D	18,5	2945	31,7	60,0	0,91	92,4	92,7	92,3	8,9	3,1	4,2	0,04409	95,2	69
	3EL180M2B	22,0	2957	38,1	71,1	0,90	92,7	92,9	92,0	8,6	3,1	3,9	0,06299	131	70
	3EL200L2B	30,0	2965	52,0	96,6	0,89	93,6	93,8	93,6	8,6	3,2	3,5	0,16168	181	72
	3EL200L2C	37,0	2965	63,3	119	0,90	93,7	94,1	93,8	8,6	3,2	3,4	0,17458	191	72
	3EG225M2C	45,0	2970	76,8	145	0,90	94,0	94,4	94,2	8,6	3,3	3,1	0,25353	335	74
	3EG250M2C	55,0	2970	93,3	177	0,90	94,4	94,8	94,5	8,6	3,3	3,4	0,38000	425	75

Our UL approved motors have the  logo on their nameplates.

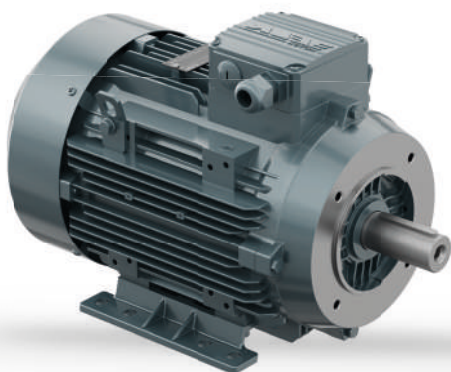

# Electrical Characteristics

400V 50Hz 1500 rpm

Duty Cycle : S1 (Continuous Operation)  
 Insulation Class : F (155°C)  
 Temperature Raise : B (80°K)



Voltage (V)	Type	Rated Values								Starting Values		Break Down Torque	Moment of Inertia	B3 Motor Weight	Sound Pressure Level
		Power	Speed	Current	Torque	Power Factor	Efficiency % $\eta$			Current	Torque				
		kW	rpm	A	Nm	Cos $\phi$	4/4	3/4	1/2	I <sub>A</sub> /I <sub>N</sub>	M <sub>A</sub> /M <sub>N</sub>				
230/400	3EL063M4B	0,12	1405	0,37	0,82	0,70	66,0	64,9	58,2	3,7	2,3	2,7	0,00018	4,10	42
	3EL063M4C	0,18	1405	0,52	1,22	0,71	69,9	68,8	63,6	3,8	2,3	2,8	0,00022	4,50	42
	3EL071M4C	0,25	1435	0,67	1,66	0,71	76,0	75,4	71,5	5,4	2,1	2,8	0,00082	7,10	45
	3EL071M4D	0,37	1435	0,97	2,46	0,70	78,5	78,2	75,0	5,5	2,2	2,9	0,00093	7,80	45
	3EL080M4C	0,55	1450	1,34	3,62	0,73	80,8	80,4	77,0	5,9	2,1	3,0	0,00200	10,5	50
	3EL080M4D	0,75	1450	1,77	4,94	0,74	82,5	82,3	80,0	6,2	2,5	3,1	0,00227	11,6	50
	3EL090S4C	1,10	1450	2,51	7,25	0,75	84,5	84,3	82,0	7,0	2,6	3,4	0,00355	16,3	51
	3EL090L4D	1,50	1445	3,30	9,91	0,77	85,3	85,2	83,0	7,2	2,8	3,4	0,00411	18,0	51
	3EL100L4C	2,20	1450	4,65	14,5	0,79	86,7	87,2	86,0	7,2	2,8	3,6	0,00775	24,4	53
	3EL100L4D	3,00	1450	6,26	19,8	0,79	87,7	88,0	87,0	7,2	2,8	3,6	0,00888	27,0	53
400/690	3EL112M4D	4,00	1460	8,05	26,2	0,81	88,6	88,4	87,5	7,4	2,8	3,8	0,01437	32,6	58
	3EL132S4C	5,50	1465	10,9	36,0	0,81	89,6	90,2	90,0	7,0	3,0	3,3	0,03059	53,4	61
	3EL132M4D	7,50	1465	14,8	48,9	0,81	90,4	91,0	90,5	7,8	3,2	3,4	0,03418	56,6	61
	3EL160M4C	11,0	1465	21,0	71,7	0,83	91,5	92,1	91,7	7,6	2,8	3,3	0,07011	89,2	63
	3EL160L4E	15,0	1465	28,7	97,8	0,82	92,1	92,4	91,9	7,8	2,8	3,5	0,08579	97,5	63
	3EL180M4C	18,5	1475	35,0	120	0,82	92,6	93,2	92,9	7,7	3,0	3,3	0,12901	128	64
	3EL180L4D	22,0	1470	41,4	143	0,82	93,0	93,7	93,7	8,0	3,0	3,4	0,14667	141	64
	3EL200L4D	30,0	1475	54,5	194	0,85	93,6	94,1	94,0	8,0	3,0	3,4	0,28413	193	65
	3EG225S4C	37,0	1478	65,7	239	0,87	93,9	94,5	94,5	8,3	3,2	3,3	0,38229	320	66
	3EG225M4D	45,0	1477	80,0	291	0,86	94,2	94,7	94,7	8,6	3,3	3,2	0,44100	350	67
3EG250M4D	55,0	1482	95,3	354	0,88	94,6	95,1	95,2	8,7	3,3	3,2	0,73000	460	68	

Our UL approved motors have the  logo on their nameplates.

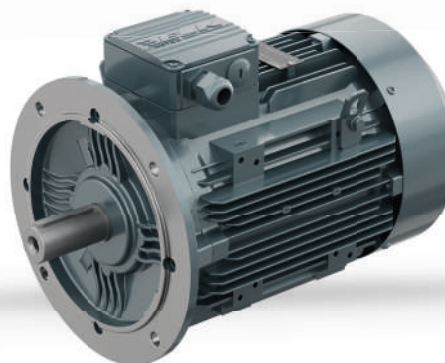

# Electrical Characteristics

Duty Cycle : S1 (Continuous Operation)  
 Insulation Class : F (155°C)  
 Temperature Raise : B (80°K)



400V 50Hz 1000 rpm

Voltage (V)	Type	Rated Values								Starting Values		Break Down Torque	Moment of Inertia	B3 Motor Weight	Sound Pressure Level
		Power	Speed	Current	Torque	Power Factor	Efficiency % $\eta$			Current	Torque				
		kW	rpm	A	Nm	Cos $\phi$	4/4	3/4	1/2	I <sub>A</sub> /I <sub>N</sub>	M <sub>A</sub> /M <sub>N</sub>				
230/400	3EL071M6C	0,18	930	0,55	1,85	0,69	68,0	67,4	62,6	3,6	2,0	2,4	0,00096	6,80	41
	3EL071M6D	0,25	930	0,77	2,57	0,67	70,0	69,7	66,0	3,6	2,2	2,5	0,00116	7,50	41
	3EL080M6B	0,37	930	1,03	3,80	0,70	74,0	73,8	70,0	4,4	2,1	2,6	0,00202	9,90	43
	3EL080M6C	0,55	935	1,47	5,62	0,70	77,2	77,3	74,4	4,3	2,2	2,7	0,00228	11,0	43
	3EL090S6B	0,75	945	1,96	7,58	0,70	78,9	79,2	77,6	4,7	2,2	2,7	0,00354	16,0	46
	3EL090L6C	1,10	940	2,75	11,2	0,71	81,0	80,8	79,4	5,0	2,2	2,7	0,00428	16,8	46
	3EL100L6B	1,50	955	3,50	15,0	0,75	82,5	82,7	81,4	5,3	2,1	2,8	0,00821	22,5	50
3EL112M6B	2,20	960	4,95	21,9	0,76	84,3	84,5	83,5	5,5	2,2	3,0	0,01319	29,6	56	
400/690	3EL132S6B	3,00	970	6,55	29,4	0,77	85,6	85,5	84,5	6,2	2,1	3,0	0,03051	46,7	58
	3EL132M6C	4,00	970	8,52	39,4	0,78	86,8	87,0	85,5	6,2	2,2	2,9	0,03493	50,9	58
	3EL132M6D	5,50	965	11,6	54,4	0,78	88,0	88,9	88,5	6,2	2,2	2,8	0,03934	57,3	58
	3EL160M6D	7,50	972	15,6	73,7	0,78	89,1	89,4	88,4	6,3	2,6	3,0	0,07870	96,0	61
	3EL160L6E	11,0	972	23,1	108	0,76	90,3	90,9	90,5	6,6	2,9	3,1	0,08580	104	62
	3EL180L6E	15,0	975	30,8	147	0,77	91,2	91,6	91,0	6,7	2,9	3,1	0,15264	141	63
	3EL200L6C	18,5	977	36,4	181	0,80	91,7	91,8	91,8	6,1	2,6	2,6	0,36100	164	64
	3EL200L6D	22,0	978	42,5	215	0,81	92,2	92,9	93,0	6,2	2,6	2,6	0,39355	180	64
	3EG225S6C	30,0	985	57,6	291	0,81	92,9	92,9	92,6	6,6	2,9	2,7	0,60000	340	65
	3EG250M6C	37,0	988	68,8	358	0,83	93,4	93,6	93,5	7,3	2,9	2,8	0,82000	435	65
	3EG280S6B	45,0	989	83,5	435	0,83	93,7	93,9	93,2	6,8	2,9	2,8	1,45000	590	65
	3EG280M6C	55,0	989	102	531	0,83	94,1	94,4	93,5	6,9	2,9	2,8	1,65000	620	65

Our UL approved motors have the  logo on their nameplates.



# Electrical Characteristics

400V 50Hz 3000 rpm

Duty Cycle : S1 (Continuous Operation)  
 Insulation Class : F (155°C)  
 Temperature Raise : B (80°K)

Compact IE3

Voltage (V)	Type	Rated Values								Starting Values		Break Down Torque	Moment of Inertia	B3 Motor Weight	Sound Pressure Level
		Power	Speed	Current	Torque	Power Factor	Efficiency % $\eta$			Current	Torque				
		kW	rpm	A	Nm	Cos $\phi$	4/4	3/4	1/2	I <sub>A</sub> /I <sub>N</sub>	M <sub>A</sub> /M <sub>N</sub>				
230/400	3EC071M2C	0,75	2810	1,66	2,55	0,81	80,7	81,0	80,3	5,0	2,6	3,1	0,00046	7,20	55
	3EC080M2D	1,50	2850	3,06	5,03	0,84	84,2	84,8	84,2	6,4	3,2	3,6	0,00135	11,8	59
	3EC090L2D	3,00	2875	5,92	9,96	0,84	87,1	87,7	87,5	7,3	3,2	3,8	0,00234	19,2	63
400/690	3EC100L2D	4,00	2900	7,53	13,2	0,87	88,1	89,1	88,6	8,4	3,2	4,2	0,00503	25,4	66
	3EC112M2D	5,50	2940	10,4	17,9	0,86	90,0	90,3	89,3	8,9	3,2	4,4	0,00734	32,0	68
	3EC112M2E**	7,50	2930	14,0	24,4	0,86	90,1	90,6	90,0	9,2	3,3	4,4	0,00920	40,5	69
	3EC132M2C	9,00	2940	16,3	29,2	0,87	90,6	90,9	90,1	8,9	3,3	4,4	0,02104	52,0	69
	3EC132M2D	11,0	2940	19,8	35,7	0,88	91,2	91,9	91,5	8,9	3,2	4,4	0,02290	55,5	69
	3EC132M2F**	15,0	2945	26,9	48,6	0,88	91,9	92,6	92,4	9,4	3,6	4,6	0,02910	69,0	70
	3EC160L2E	22,0	2940	38,1	71,5	0,90	92,7	93,2	92,8	8,9	3,3	4,4	0,04710	114	70
	3EC180M2C	30,0	2955	51,0	96,9	0,91	93,3	93,9	93,8	9,0	3,5	4,4	0,08800	150	74
	3EC200L2D	45,0	2970	78,1	145	0,89	94,0	94,9	94,7	9,0	3,6	3,5	0,18700	200	77
	3ED225M2C	55,0	2970	94,6	177	0,89	94,3	94,8	94,6	9,0	3,6	3,5	0,25300	335	78
	3ED315L2F*	250	2982	414	801	0,91	95,8	95,6	95,2	8,7	3,0	3,3	2,80000	1410	81

400V 50Hz 1500 rpm

Duty Cycle : S1 (Continuous Operation)  
 Insulation Class : F (155°C)  
 Temperature Raise : B (80°K)

Compact IE3

Voltage (V)	Type	Rated Values								Starting Values		Break Down Torque	Moment of Inertia	B3 Motor Weight	Sound Pressure Level
		Power	Speed	Current	Torque	Power Factor	Efficiency % $\eta$			Current	Torque				
		kW	rpm	A	Nm	Cos $\phi$	4/4	3/4	1/2	I <sub>A</sub> /I <sub>N</sub>	M <sub>A</sub> /M <sub>N</sub>				
230/400	3EC071M4E**	0,55	1425	1,39	3,69	0,71	80,8	80,9	78,2	5,3	2,8	3,1	0,00122	9,00	50
	3EC090L4F**	2,20	1435	4,66	14,6	0,79	86,7	84,7	84,0	6,9	3,2	3,5	0,00513	20,9	61
400/690	3EC112M4F**	5,50	1455	11,1	36,1	0,80	89,6	90,2	89,6	7,4	3,1	3,8	0,01620	38,6	64
	3EC132M4E	9,00	1460	17,9	58,9	0,80	90,8	91,6	91,2	7,4	3,1	3,4	0,03600	61,4	64
	3EC132M4F**	11,0	1465	21,7	71,7	0,80	91,4	91,6	91,5	7,4	3,1	3,4	0,04320	72,5	64
	3EC160L4F**	18,5	1465	35,8	121	0,81	92,6	93,1	92,8	7,4	3,1	3,4	0,09300	113	65
	3EC180L4E	30,0	1470	58,0	195	0,80	93,6	94,1	93,9	7,8	3,2	3,4	0,16400	164	66
	3EC200L4D	37,0	1475	66,1	240	0,86	93,9	94,7	94,9	7,8	3,2	3,4	0,28400	194	68
	3ED225M4E	55,0	1480	97,7	355	0,86	94,6	95,2	95,4	8,0	3,6	3,5	0,50200	370	70
	3ED315L4G*	250	1492	442	1600	0,85	96,0	96,1	95,6	8,1	3,0	3,4	5,47000	1530	75

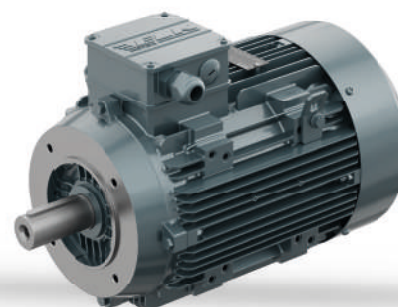

Motors marked with \* have Class H insulation and Class F temperature rise values.  
 Motors marked with \*\* do not have a symmetrical frame structure.

**THREE-PHASE MOTORS**



**IE4**

**Motors**

# Electrical Characteristics

Duty Cycle : S1 (Continuous Operation)  
 Insulation Class : F (155°C)  
 Temperature Raise : B (80°K)



400V 50Hz 3000 rpm

Voltage (V)	Type	Rated Values								Starting Values		Break Down Torque	Moment of Inertia	B3 Motor Weight	Sound Pressure Level
		Power	Speed	Current	Torque	Power Factor	Efficiency % $\eta$			Current	Torque				
		kW	rpm	A	Nm	Cos $\phi$	4/4	3/4	1/2	I <sub>A</sub> /I <sub>N</sub>	M <sub>A</sub> /M <sub>N</sub>				
230/400	4EL071M2B	0,37	2825	0,83	1,25	0,82	78,1	78,3	76,5	5,7	2,8	3,2	0,00037	6,50	58
	4EL071M2C	0,55	2825	1,17	1,86	0,83	81,5	81,9	79,5	6,2	2,9	3,5	0,00046	7,50	58
	4EL080M2C	0,75	2875	1,56	2,49	0,83	83,5	84,0	81,0	6,8	2,9	3,5	0,00124	11,0	59
	4EL080M2D	1,10	2880	2,19	3,65	0,85	85,2	85,5	84,9	7,5	2,9	3,7	0,00135	12,0	59
	4EL090S2C	1,50	2900	2,95	4,94	0,85	86,5	86,9	85,7	7,8	2,9	3,7	0,00221	17,2	64
	4EL090L2D	2,20	2900	4,20	7,24	0,86	88,0	88,5	87,6	8,2	3,0	3,8	0,00234	20,0	64
	4EL100L2D	3,00	2910	5,50	9,85	0,88	89,1	89,5	88,5	8,5	3,0	4,0	0,00503	25,9	67
400/690	4EL112M2D	4,00	2940	7,30	13,0	0,88	90,0	90,3	89,7	8,7	3,0	4,2	0,00734	32,2	70
	4EL132S2C	5,50	2945	9,60	17,8	0,91	90,9	90,9	90,0	8,9	3,2	4,2	0,02104	52,5	72
	4EL132S2D	7,50	2945	13,0	24,5	0,91	91,7	92,2	91,8	8,5	3,2	4,2	0,02290	55,6	72
	4EL160M2C	11,0	2950	18,9	35,6	0,91	92,6	92,7	91,2	8,5	3,3	4,3	0,03913	89,0	74
	4EL160M2D	15,0	2950	25,6	48,6	0,91	93,3	93,6	92,8	8,5	3,3	4,3	0,04409	96,8	74
	4EL160L2E	18,5	2955	31,4	59,8	0,91	93,7	93,8	92,9	8,7	3,2	4,3	0,05000	114	74
	4EL180M2C	22,0	2960	37,2	71,1	0,91	94,0	94,4	93,5	8,9	3,0	4,0	0,07000	158	74
	4EL200L2C	30,0	2970	51,0	96,5	0,90	94,5	94,7	94,0	8,3	3,2	3,7	0,17500	215	74
	4EL200L2D	37,0	2970	63,3	120	0,89	94,8	95,0	94,2	8,3	3,2	4,0	0,20000	235	74
	4EG225M2D	45,0	2975	76,0	145	0,90	95,0	95,2	94,9	9,0	3,4	4,2	0,29000	355	74
	4EG250M2D	55,0	2975	92,6	177	0,90	95,3	95,5	94,9	8,2	3,4	3,7	0,52000	445	74
	4EG280S2C	75,0	2982	126	240	0,90	95,6	95,6	95,2	7,7	2,7	3,2	0,98000	620	76
	4EG280M2D	90,0	2985	151	288	0,90	95,8	95,9	95,0	7,7	2,8	3,5	1,10000	640	77
	4EG315S2C	110	2985	184	352	0,90	96,0	96,0	95,7	7,8	3,1	4,0	1,60000	1110	77
	4EG315M2D	132	2986	220	422	0,90	96,2	96,3	96,0	8,0	3,1	4,0	2,00000	1070	77
	4EG315L2E	160	2986	267	512	0,90	96,3	96,5	96,0	8,0	3,2	4,0	2,20000	1230	78
	4EG315L2F	200	2987	332	639	0,90	96,5	96,7	96,3	8,1	3,2	4,0	2,70000	1340	78

Our UL approved motors have the  logo on their nameplates.



# Electrical Characteristics

400V 50Hz 1500 rpm

Duty Cycle : S1 (Continuous Operation)  
 Insulation Class : F (155°C)  
 Temperature Raise : B (80°K)



Voltage (V)	Type	Rated Values								Starting Values		Break Down Torque	Moment of Inertia	B3 Motor Weight	Sound Pressure Level
		Power	Speed	Current	Torque	Power Factor	Efficiency % $\eta$			Current	Torque				
		kW	rpm	A	Nm	Cos $\phi$	4/4	3/4	1/2	I <sub>A</sub> /I <sub>N</sub>	M <sub>A</sub> /M <sub>N</sub>				
400/690	4EL132S4D	5,50	1470	11,1	35,7	0,78	91,9	91,8	90,6	7,7	3,8	3,7	0,03418	56,7	61
	4EL132M4F*	7,50	1470	14,6	48,7	0,80	92,6	92,7	91,5	7,7	3,8	4,0	0,04316	72,8	62
	4EL160M4E	11,0	1470	21,0	71,5	0,81	93,3	93,5	93,3	7,7	3,0	3,6	0,08600	100	64
	4EL160L4F*	15,0	1475	29,5	97,5	0,79	93,9	94,1	93,4	8,0	3,7	3,9	0,12000	112	64
	4EL180M4D	18,5	1475	34,6	120	0,82	94,2	94,4	94,0	8,0	3,1	3,5	0,14700	142	64
	4EL180L4E	22,0	1475	41,0	142	0,82	94,5	94,7	94,2	8,2	3,2	3,8	0,17000	168	64
	4EL200L4E	30,0	1480	53,0	194	0,86	94,9	95,3	95,2	8,3	3,3	3,8	0,35000	235	64
	4EG225S4D	37,0	1480	65,0	239	0,86	95,2	95,7	95,0	8,1	3,3	3,3	0,44100	350	70
	4EG225M4E	45,0	1480	79,2	290	0,86	95,4	95,6	95,6	8,2	3,5	3,3	0,52000	370	70
	4EG250M4E	55,0	1485	94,3	354	0,88	95,7	96,0	96,0	8,5	3,3	3,4	1,05000	490	70
	4EG280S4D	75,0	1487	127	482	0,89	96,0	96,3	96,2	8,7	3,0	3,2	1,50000	670	70
	4EG280M4E	90,0	1488	152	578	0,89	96,1	96,3	96,3	8,9	3,1	3,2	1,95000	720	71
	4EG315S4D	110	1491	187	705	0,88	96,3	96,5	96,0	8,9	2,8	3,3	2,80000	1200	73
	4EG315M4E	132	1492	225	845	0,88	96,4	96,7	96,2	8,9	2,9	3,3	3,30000	1270	73
	4EG315L4F	160	1492	272	1024	0,88	96,6	96,9	96,5	8,9	3,1	3,4	4,40000	1370	76
	4EG315L4G	200	1492	339	1280	0,88	96,7	97,0	96,6	8,8	3,3	3,5	5,20000	1520	76

Our UL approved motors have the  logo on their nameplates.



Motors marked with \* do not have a symmetrical frame structure.

# Electrical Characteristics

Duty Cycle : S1 (Continuous Operation)  
 Insulation Class : F (155°C)  
 Temperature Raise : B (80°K)



400V 50Hz 1000 rpm

Voltage (V)	Type	Rated Values								Starting Values		Break Down Torque	Moment of Inertia	B3 Motor Weight	Sound Pressure Level
		Power	Speed	Current	Torque	Power Factor	Efficiency % $\eta$			Current	Torque				
		kW	rpm	A	Nm	Cos $\phi$	4/4	3/4	1/2	I <sub>A</sub> /I <sub>N</sub>	M <sub>A</sub> /M <sub>N</sub>				
400 / 690	4EG315S6C	75,0	994	133	721	0,85	95,4	95,5	95,2	8,80	2,80	3,50	3,50000	1215	67
	4EG315M6D	90,0	994	160	865	0,85	95,6	95,7	95,8	8,80	2,80	3,70	3,80000	1250	67
	4EG315L6E	110	995	195	1056	0,85	95,8	96,1	95,7	8,60	2,80	3,70	4,50000	1280	68
	4EG315L6F	132	995	231	1267	0,86	96,0	96,2	95,8	8,50	2,80	3,70	5,20000	1350	68
	4EG315L6G	160	995	280	1536	0,86	96,2	96,4	96,3	7,70	2,90	3,80	5,55000	1446	70

Our UL approved motors have the  logo on their nameplates.



**THREE-PHASE MOTORS**



**Dimensions**

# B3 Construction Types

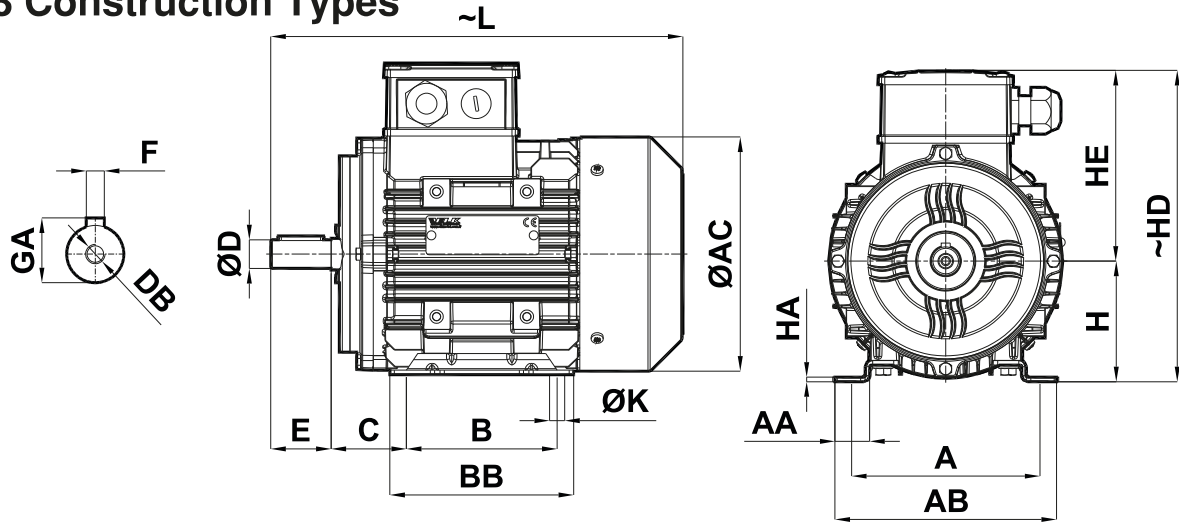

Frame Size	Efficiency Class	No. of Poles	D <sup>[1]</sup>	E	L	AC	H <sup>[2]</sup>	HE	HD	F	GA	DB	C	ØK	B	BB	HA	AA	A	AB
063M	IE2/IE3	2-4	11	23	213	119	63	101	164	4	12,5	M4	40	7	80	104	3	18	100	115
071M	IE2/IE3/IE4	2-4-6-8	14	30	242	137	71	118	189	5	16	M5	45	7	90	110	3	19	112	128
071M <sup>[3]</sup>	IE3C	4	14	30	272	137	71	118	189	5	16	M5	45	7	90	110	3	19	112	128
080M	IE2/IE3/IE4	2-4-6-8	19	40	274	155	80	127	207	6	21,5	M6	50	10	100	122	3	25	125	148
090S	IE3/IE4	2-4-6-8	24	50	325	176	90	136	226	8	27	M8	56	10	100	151	4	27	140	167
090L	IE3/IE4	2-4-6-8	24	50	325	176	90	136	226	8	27	M8	56	10	125	151	4	27	140	167
090L <sup>[4]</sup>	IE3C	4	24	50	351	176	90	136	226	8	27	M8	56	10	125	151	4	27	140	167
100L	IE3/IE4	2-4-6-8	28	60	369	193	100	149	249	8	31	M10	63	12	140	170	4	31	160	191
112M	IE3/IE3C/IE4	2-4-6-8	28	60	392	215	112	161	273	8	31	M10	70	12	140	177	4	36	190	217
112M <sup>[5]</sup>	IE3C/IE4	4	28	60	430	215	112	161	273	8	31	M10	70	12	140	177	4	36	190	217
132S	IE3/IE4	2-4-6-8	38	80	495	257	132	182	314	10	41	M12	89	12	140	212	5	34	216	246
132M	IE3/IE3C/IE4	2-4-6-8	38	80	495	257	132	182	314	10	41	M12	89	12	178	212	5	34	216	246
132M <sup>[6]</sup>	IE3C/IE4	4	38	80	543	257	132	182	314	10	41	M12	89	12	178	212	5	34	216	246
160M	IE3/IE4	2-4-6-8	42	110	605	316	160	226	386	12	45	M16	108	14,5	210	328	15	65	254	293
160L	IE3/IE3C/IE4	2-4-6-8	42	110	605	316	160	226	386	12	45	M16	108	14,5	254	328	15	65	254	293
160L <sup>[7]</sup>	IE3C/IE4	4	42	110	657	316	160	226	386	12	45	M16	108	14,5	254	328	15	65	254	293
180M	IE3/IE4	2-4-6-8	48	110	696	348	180	242	422	14	51,5	M16	121	14,5	241	319	15	63	279	316
180L	IE3/IE4	2-4-6-8	48	110	696	348	180	242	422	14	51,5	M16	121	14,5	279	319	15	63	279	316
200M	IE3/IE4	2-4-6-8	55	110	737	396	200	294	494	16	59	M20	133	18,5	267	350	20	76	318	372
200L	IE3/IE4	2-4-6-8	55	110	737	396	200	294	494	16	59	M20	133	18,5	305	350	20	76	318	372
225S	IE3/IE4	2	55	110	800	438	225	311,5	536,5	16	59	M20	149	18,5	286	360	20	90	356	417
		4-6-8	60	140	830					18	64									
225M	IE3/IE4	2	55	110	800	438	225	311,5	536,5	16	59	M20	149	18,5	311	360	20	90	356	417
		4-6-8	60	140	830					18	64									
250S	IE3/IE4	2	60	140	896	481	250	337	587	18	64	M20	168	24	311	433	32	105	406	475
		4-6-8	65	140	896					18	69									
250M	IE3/IE4	2	60	140	896	481	250	337	587	18	64	M20	168	24	349	433	32	105	406	475
		4-6-8	65	140	896					18	69									
280S	IE3/IE4	2	65	140	1012	547	280	402	682	18	69	M20	190	24	368	500	35	105	457	531
		4-6-8	75	140	1012					20	79,5									
280M	IE3/IE4	2	65	140	1012	547	280	402	682	18	69	M20	190	24	419	500	35	105	457	531
		4-6-8	75	140	1012					20	79,5									
315S	IE3/IE4	2	65	140	1242	622	315	499	814	18	69	M20	216	28	406	636	33	157	508	626
		4-6-8	80	170	1272					22	85									
315M	IE3/IE4	2	65	140	1242	622	315	499	814	18	69	M20	216	28	457	636	33	157	508	626
		4-6-8	80	170	1272					22	85									
315L	IE3/IE4	2	65	140	1389	622	315	499	814	18	69	M20	216	28	508	800	35	145	508	623
		4-6-8	90	170	1419					25	95									

1 Tolerance "j6" up to 28mm, "k6" from 28mm to 48mm, "m6" over 48mm TS EN 50347

2 Tolerance 063-250 "-0.5mm" / 280-315 "-1mm" TS EN 50347

3 0.55kW IE3 Compact Motors

4 2.20kW IE3 Compact Motors

5 5.50kW IE3 Compact Motors

6 11.0kW IE3 Compact Motors / 7.50kW IE4 Motors

7 18.5kW IE3 Compact Motors / 15.0kW IE4 Motors

## B5- B35 Construction Types

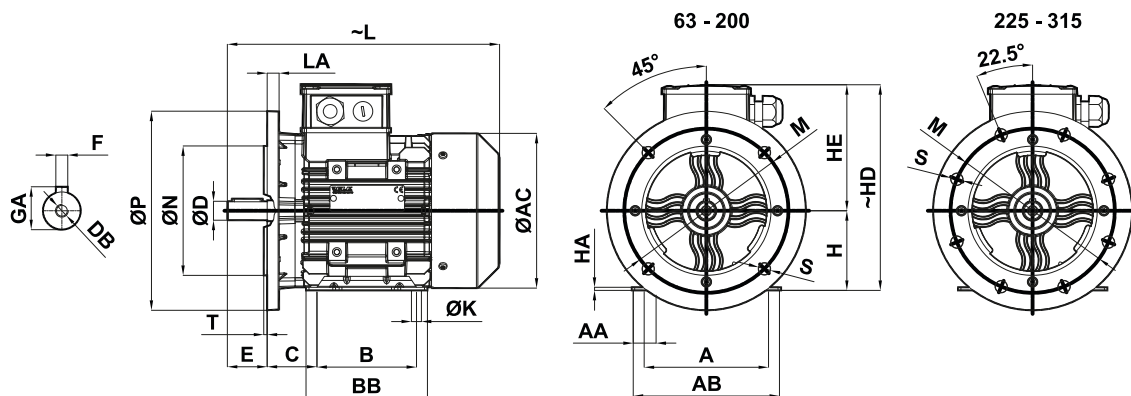

Frame Size	Efficiency Class	No. of Poles	D <sup>[1]</sup>	E	N <sup>[2]</sup>	P	T	LA	L	AC	S	M	H <sup>[3]</sup>	HE	HD	F	GA	DB	C	ØK	B	BB	HA	AA	A	AB
063M	IE2/IE3	2-4	11	23	95	140	3	8	213	119	10	115	63	101	160	4	12,5	M4	40	7	80	104	3	18	100	115
071M	IE2/IE3/IE4	2-4-6-8	14	30	110	160	3,5	8	242	137	10	130	71	118	183	5	16	M5	45	7	90	110	3	19	112	128
071M <sup>[4]</sup>	IE3C	4	14	30	110	160	3,5	8	272	137	10	130	71	118	183	5	16	M5	45	7	90	110	3	19	112	128
080M	IE2/IE3/IE4	2-4-6-8	19	40	130	200	3,5	12	274	155	12	165	80	127	207	6	21,5	M6	50	10	100	122	3	25	125	148
090S	IE3/IE4	2-4-6-8	24	50	130	200	3,5	12	325	176	12	165	90	136	226	8	27	M8	56	10	100	151	4	27	140	167
090L	IE3/IE4	2-4-6-8	24	50	130	200	3,5	12	325	176	12	165	90	136	226	8	27	M8	56	10	125	151	4	27	140	167
090L <sup>[5]</sup>	IE3C	4	24	50	130	200	3,5	12	351	176	12	165	90	136	226	8	27	M8	56	10	125	151	4	27	140	167
100L	IE3/IE4	2-4-6-8	28	60	180	250	4	15	369	193	14,5	215	100	149	248	8	31	M10	63	12	140	170	4	31	160	191
112M	IE3/IE3C/IE4	2-4-6-8	28	60	180	250	4	15	392	215	14,5	215	112	161	273	8	31	M10	70	12	140	177	4	36	190	217
112M <sup>[6]</sup>	IE3C/IE4	4	28	60	180	250	4	15	430	215	14,5	215	112	161	273	8	31	M10	70	12	140	177	4	36	190	217
132S	IE3/IE4	2-4-6-8	38	80	230	300	4	20	495	257	14,5	265	132	182	312	10	41	M12	89	12	140	212	5	34	216	246
132M	IE3/IE3C/IE4	2-4-6-8	38	80	230	300	4	20	495	257	14,5	265	132	182	312	10	41	M12	89	12	178	212	5	34	216	246
132M <sup>[7]</sup>	IE3C/IE4	4	38	80	230	300	4	20	543	257	14,5	265	132	182	312	10	41	M12	89	12	178	212	5	34	216	246
160M	IE3/IE4	2-4-6-8	42	110	250	350	5	20	605	316	18,5	300	160	226	380	12	45	M16	108	14,5	210	328	15	65	254	293
160L	IE31/IE3C/IE4	2-4-6-8	42	110	250	350	5	20	605	316	18,5	300	160	226	380	12	45	M16	108	14,5	254	328	15	65	254	293
160L <sup>[8]</sup>	IE4	4	42	110	250	350	5	20	657	316	18,5	300	160	226	380	12	45	M16	108	14,5	254	328	15	65	254	293
180M	IE3/IE4	2-4-6-8	48	110	250	350	5	14	696	348	18,5	300	180	242	419	14	51,5	M16	121	14,5	241	319	15	63	279	316
180L	IE3/IE4	2-4-6-8	48	110	250	350	5	14	696	348	18,5	300	180	242	419	14	51,5	M16	121	14,5	279	319	15	63	279	316
200M	IE3/IE4	2-4-6-8	55	110	300	400	5	14	737	396	18,5	350	200	294	494	16	59	M20	133	18,5	267	350	20	76	318	372
200L	IE3/IE4	2-4-6-8	55	110	300	400	5	14	737	396	18,5	350	200	294	494	16	59	M20	133	18,5	305	350	20	76	318	372
225S	IE3/IE4	2	55	110	350	450	5	20	800	438	18,5	400	225	312	537	18	16	M20	149	18,5	286	360	20	90	356	417
		830	64																							
225M	IE3/IE4	2	55	110	350	450	5	20	800	438	18,5	400	225	312	537	18	16	M20	149	18,5	311	360	20	90	356	417
		830	64																							
250S	IE3/IE4	2	60	140	450	550	5	20	896	481	18,5	500	250	337	587	18	64	M20	168	24	311	433	32	105	406	475
		69	64																							
250M	IE3/IE4	2	60	140	450	550	5	20	896	481	18,5	500	250	337	587	18	64	M20	168	24	349	433	32	105	406	475
		69	64																							
280S	IE3/IE4	2	65	140	450	550	5	20	1012	547	18,5	500	280	402	682	18	69	M20	190	24	368	500	35	105	457	531
		79,5	69																							
280M	IE3/IE4	2	65	140	450	550	5	20	1012	547	18,5	500	280	402	682	18	69	M20	190	24	419	500	35	105	457	531
		79,5	69																							
315S	IE3/IE4	2	65	140	550	660	6	25	1242	622	24	600	315	499	814	18	69	M20	216	28	406	636	33	157	508	626
		85	85																							
315M	IE3/IE4	2	65	140	550	660	6	22	1242	622	24	600	315	499	814	18	69	M20	216	28	457	636	33	157	508	626
		85	85																							
315L	IE3/IE4	2	65	140	550	660	6	22	1389	622	24	600	315	499	814	18	69	M20	216	28	508	800	35	145	508	623
		95	95																							

1 Tolerance "j6" up to 28mm, "k6" from 28mm to 48mm, "m6" over 48mm TS EN 50347

2 Tolerance "j6" up to 250mm, "h6" over 250mm TS EN 50347

3 Tolerance 063-250 "-0.5mm" / 280-315 "-1mm" TS EN 50347

4 0.55kW IE3 Compact Motors

5 2.20kW IE3 Compact Motors

6 5.50kW IE3 Compact Motors

7 11.0kW IE3 Compact Motors / 7.50kW IE4 Motors

8 18.5kW IE3 Compact Motors / 15.0kW IE4 Motors

# B14 - B34 Construction Types

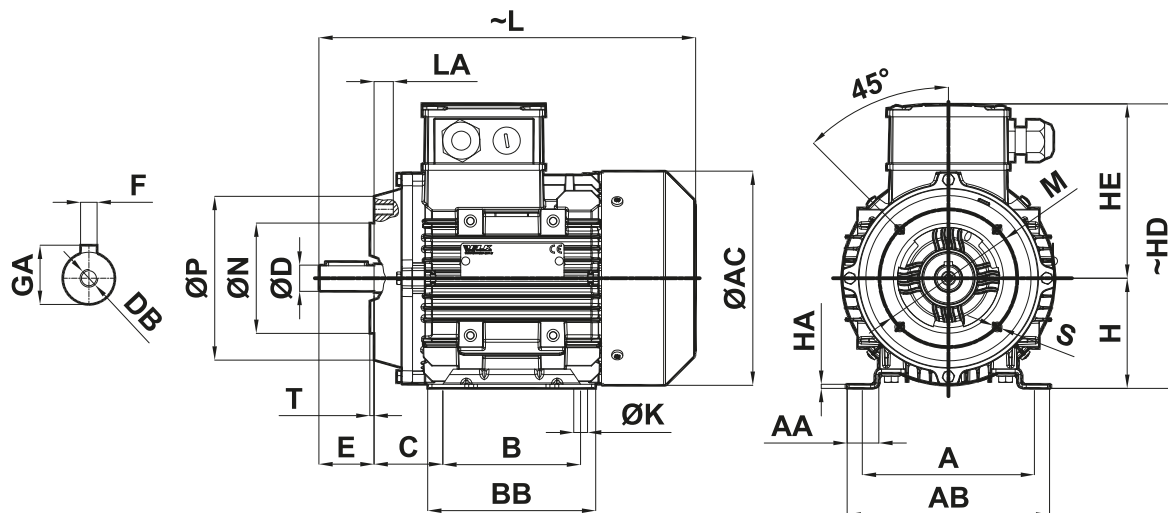

Frame Size	Efficiency Class	No. of Poles	D <sup>[1]</sup>	N <sup>[2]</sup>	P	E	T	LA	L	AC	S	M	H <sup>[3]</sup>	HE	HD	F	GA	DB	C	ØK	B	BB	HA	AA	A	AB
063M	IE2/IE3	2-4	11	60	90	23	2,5	10	213	119	M5	75	63	101	164	4	12,5	M4	40	7	80	104	3	18	100	115
071M	IE2/IE3/IE4	2-4-6-8	14	70	105	30	2,5	12	242	137	M6	85	71	118	189	5	16	M5	45	7	90	110	3	19	112	128
071M <sup>[4]</sup>	IE3C	4	14	70	105	30	2,5	12	272	137	M6	85	71	118	189	5	16	M5	45	7	90	110	3	19	112	128
080M	IE2/IE3/IE4	2-4-6-8	19	80	119	40	3	12	274	155	M6	100	80	127	207	6	21,5	M6	50	10	100	122	3	25	125	148
090S	IE3/IE4	2-4-6-8	24	95	137	50	3	15	325	176	M8	115	90	136	226	8	27	M8	56	10	100	151	4	27	140	167
090L	IE3/IE4	2-4-6-8	24	95	137	50	3	15	325	176	M8	115	90	136	226	8	27	M8	56	10	125	151	4	27	140	167
090L <sup>[5]</sup>	IE3C	4	24	95	137	50	3	15	351	176	M8	115	90	136	226	8	27	M8	56	10	125	151	4	27	140	167
100L	IE3/IE4	2-4-6-8	28	110	160	60	3,5	17	369	193	M8	130	100	149	249	8	31	M10	63	12	140	170	4	31	160	191
112M	IE3/IE3C/IE4	2-4-6-8	28	110	160	60	3,5	17	392	215	M8	130	112	161	273	8	31	M10	70	12	140	177	4	36	190	217
112M <sup>[6]</sup>	IE3C/IE4	4	28	110	160	60	3,5	17	430	215	M8	130	112	161	273	8	31	M10	70	12	140	177	4	36	190	217
132S	IE3/IE4	2-4-6-8	38	130	200	80	3,5	20	495	257	M10	165	132	182	314	10	41	M12	89	12	140	212	5	34	216	246
132M	IE3/IE3C/IE4	2-4-6-8	38	130	200	80	3,5	20	495	257	M10	165	132	182	314	10	41	M12	89	12	178	212	5	34	216	246
132M <sup>[7]</sup>	IE3C/IE4	4	38	130	200	80	3,5	20	543	257	M10	165	132	182	314	10	41	M12	89	12	178	212	5	34	216	246
160M	IE3/IE4	2-4-6-8	42	180	250	110	4	23	605	316	M12	215	160	226	386	12	45	M16	108	14,5	210	323	15	65	254	295
160L	IE3/IE3C/IE4	2-4-6-8	42	180	250	110	4	23	605	316	M12	215	160	226	386	12	45	M16	108	14,5	254	323	15	65	254	295
160L <sup>[8]</sup>	IE4	4	42	180	250	110	4	23	657	316	M12	215	160	226	386	12	45	M16	108	14,5	254	323	15	65	254	295

1 Tolerance "j6" up to 28mm, "k6" over 28mm TS EN 50347

2 Tolerance "j6" TS EN 50347

3 Tolerance "-0.5mm" TS EN 50347

4 0.55kW IE3 Compact Motors

5 2.20kW IE3 Compact Motors

6 5.50kW IE3 Compact Motors

7 11.0kW IE3 Compact Motors / 7.50kW IE4 Motors

8 18.5kW IE3 Compact Motors / 15.0kW IE4 Motors

## Three-Phase Motor Nameplate Description

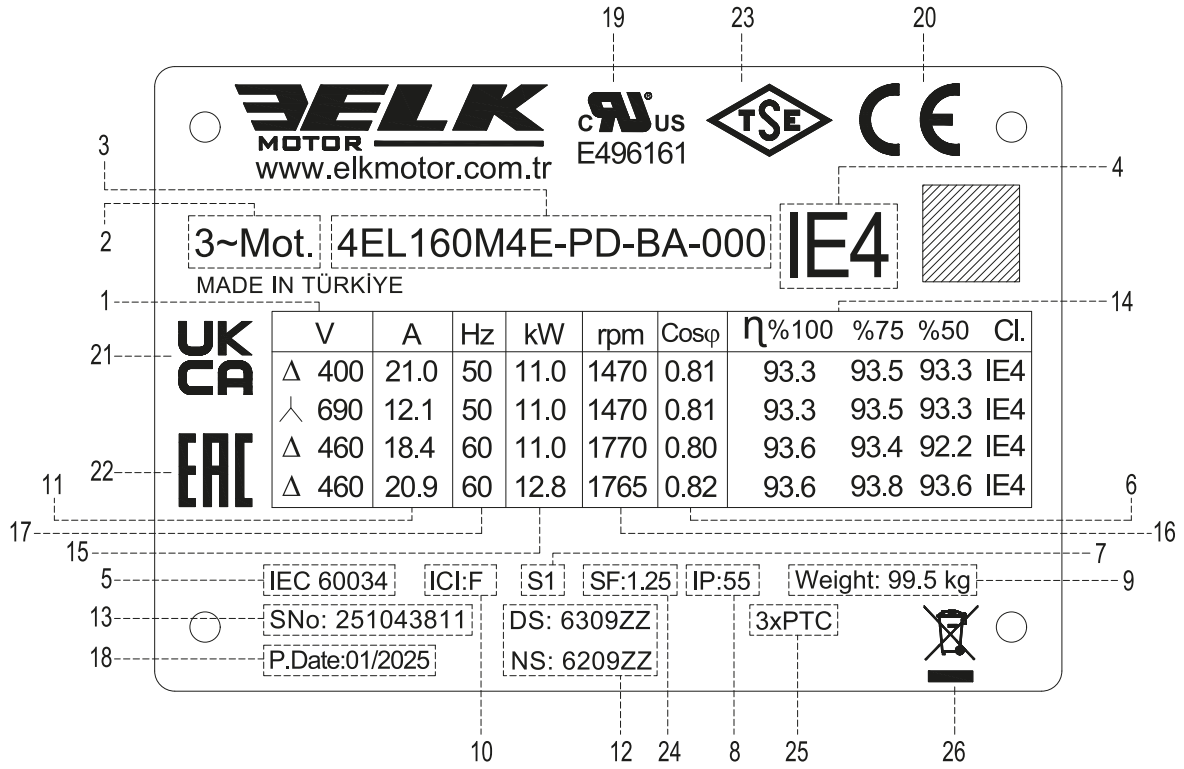

1. Rated Voltage	14. Efficiency
2. Motor Type: 3 Phase Asynchronous	15. Output Power
3. Motor Code	16. Speed
4. Efficiency Class	17. Frequency
5. Manufacture Standard	18. Production Date
6. Power Factor	19. UL Logo
7. Duty Cycle	20. CE Mark
8. Protection Class	21. UKCA Mark
9. Motor Weight	22. EAC Logo
10. Insulation Class	23. TSE Logo
11. Rated Current	24. Service Factor
12. Bearing Type	25. 3xPTC Thermistor
13. Serial Number	26. WEEE Symbol



The nameplate shows the identification, and the most important technical data. The nameplate also defines the limits of proper usage, and manufacturing year of the motors. The first two digits in the serial number, shows the manufacturing year. For example, 25XXXXXXX shows that the product is manufactured in 2025.

# Three-Phase Motors Spare Parts

All standard three-phase motors manufactured by ELK MOTOR consist of the following main components:

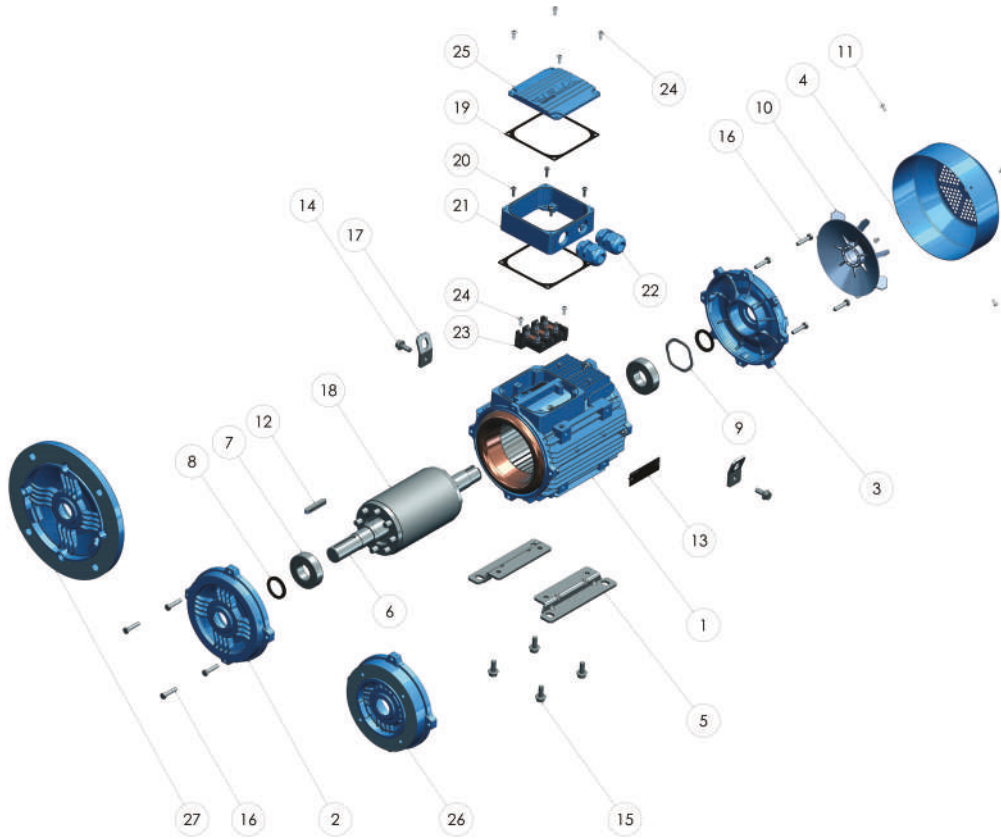

1.	Housing
2.	End Shield (DE)
3.	End Shield (NDE)
4.	Fan Cover
5.	Mounting Foot
6.	Shaft
7.	Bearing
8.	Shaft Seal
9.	Spring Washer
10.	Fan
11.	Screw
12.	Key
13.	Nameplate
14.	Screw

15.	Screw
16.	Bolt
17.	Lifting Lug
18.	Squirrel Cage Rotor
19.	Terminal Box Gasket
20.	Screw
21.	Terminal Box
22.	Cable Gland
23.	Terminal
24.	Screw
25.	Terminal Box Cover
26.	Flange B14
27.	Flange B5

When ordering spare parts, the motor serial number, full type designation, and product code, as stated on the nameplate, must be specified. For field service, spare parts and additional information, please contact with us.

**SINGLE-PHASE MOTORS**



**Technical Information**

# Electrical Construction

Our single phase standard motors have an F class (155°C) electrical insulation system. However, all standard motors in our product range operate within B class temperature rise limits. This ensures that the provided temperature class has a safety margin, allowing our motors to operate under more demanding conditions than specified or to have a longer service life under normal conditions.

Motors with H class insulation can be manufactured according to customer requirements.

# Electrical Connections

Cable Gland				
Frame Size	063	071	080	090
Cable Glands	M16x1,5	M20x1,5		

Terminal Connections				
Frame Size	063	071	080	090
Terminal Size	M4			

Our single-phase motors are manufactured with a standard voltage of 230V 50Hz and are wired to rotate clockwise when viewed from the drive end. For counterclockwise rotation, the terminal connections should be configured as specified below.

Terminal Marking Information	
U1 , U2	Main Winding Terminals
Z1 , Z2	Auxiliary Winding Terminals
Cr , Cs	Capacitor Terminals

## Terminal Connections for Single-Phase Run Capacitor Motors

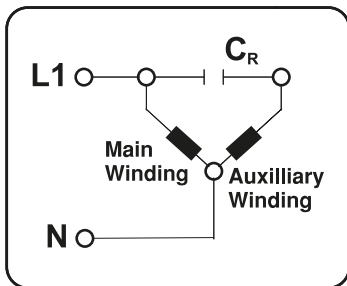

Circuit Connection

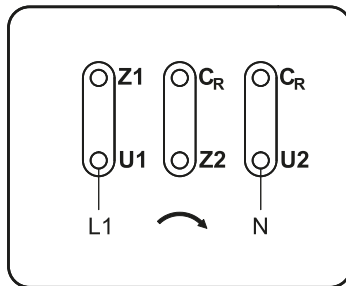

Clockwise Rotation

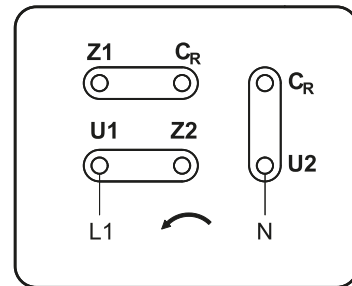

Counter-Clockwise Rotation

## Terminal Connections for Single-Phase Run and Start Capacitor Motors

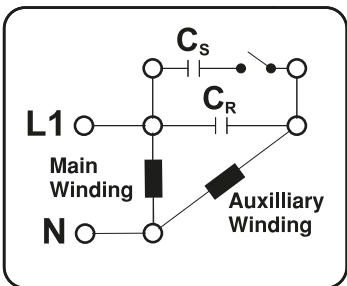

Circuit Connection

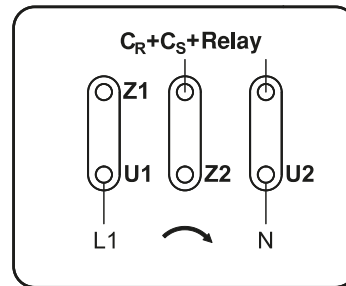

Clockwise Rotation

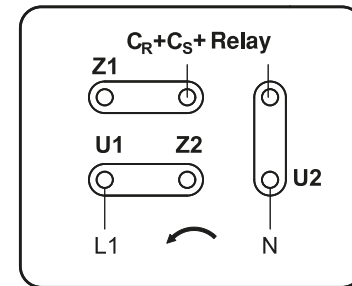

Counter-Clockwise Rotation

## Mechanical Structure

Single-phase ELK motors are equipped with a removable foot structure for the corresponding frame sizes. Due to the dimensions of the terminal box, the feet can only be mounted on the underside of the frame. Additionally, the symmetrical frame and foot design of single-phase ELK motors ensure that the C dimension remains constant when the shaft-side cover, rear cover, and shaft direction are altered. This design allows for the terminal box to be positioned either near the shaft side or the fan side.

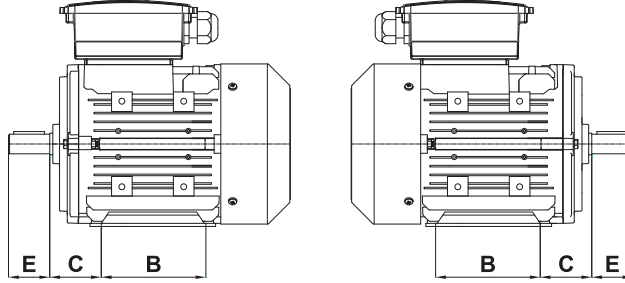

The materials used in our products are specified below.

Frame Size	Housing	End Shield DE	End Shield NDE	Terminal Box & Cover	Feet	Fan Cover	Fan
63	Aluminum	Aluminum	Aluminum	Aluminum	Steel Sheet	Steel Sheet	Plastic
71	Aluminum	Aluminum	Aluminum	Aluminum	Steel Sheet	Steel Sheet	Plastic
80	Aluminum	Aluminum	Aluminum	Aluminum	Steel Sheet	Steel Sheet	Plastic
90	Aluminum	Aluminum	Aluminum	Aluminum	Steel Sheet	Steel Sheet	Plastic

## Bearings

Single-phase ELK motors utilize deep groove ball bearings as specified in the table.

Frame Size	Number of Poles	Drive End Bearing	Non Drive End Bearing
63	2-4	6201 ZZ C3	6201 ZZ C3
71	2-4	6202 ZZ C3	6202 ZZ C3
80	2-4	6204 ZZ C3	6204 ZZ C3
90	2-4	6205 ZZ C3	6205 ZZ C3

## Shaft Seals

The shaft seals specified in the table are used in standard ELK Motors.

Frame Size	Number of Poles	Drive End Shaft Seal	Non-Drive End Shaft Seal
63	2-4	Ø12xØ24x4	Ø12xØ24x4
71	2-4	Ø15xØ30x4	Ø15xØ30x4
80	2-4	Ø20xØ30x4	Ø20xØ30x4
90	2-4	Ø25xØ35x4	Ø25xØ35x4

# Radial Loads

HORIZONTAL MOUNTING - Permissible Axial Loads  
 Mounting Positions IM: B3, B5, B6, B7, B8, B14, B34, B35

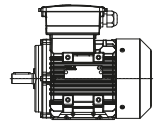

Frame Size	Fa = 0	
	 Fr <sub>0</sub>	 Fr <sub>max</sub>
<b>2 Poles 3000 rpm</b>	Fr <sub>0</sub> [N]	Fr <sub>max</sub> [N]
63	350	300
71	380	340
80	640	550
90	750	660
<b>4 Poles 1500 rpm</b>	Fr <sub>0</sub> [N]	Fr <sub>max</sub> [N]
63	430	390
71	520	440
80	800	700
90	950	780

# Axial Loads

HORIZONTAL MOUNTING - Permissible Axial Loads  
 Mounting Positions IM: B3, B5, B6, B7, B8, B14, B34, B35

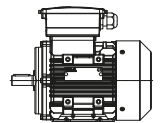

Frame Size	Push			Pull
	Fr = 0	Fr = Fr <sub>0</sub>	Fr = Fr <sub>max</sub>	Fr = 0
	 Fa <sub>0</sub>	 Fa <sub>0</sub> , Fr <sub>0</sub>	 Fa <sub>0</sub> , Fr <sub>max</sub>	 Fa <sub>0</sub>
<b>2 Poles 3000 rpm</b>	Fa <sub>0</sub> [N]	Fa <sub>0</sub> [N]	Fa <sub>0</sub> [N]	Fa <sub>0</sub> [N]
63	90	90	90	220
71	110	110	110	250
80	190	190	190	395
90	210	210	210	400
<b>4 Poles 1500 rpm</b>	Fa <sub>0</sub> [N]	Fa <sub>0</sub> [N]	Fa <sub>0</sub> [N]	Fa <sub>0</sub> [N]
63	90	90	90	330
71	110	110	110	360
80	190	190	190	560
90	210	210	210	585

Fa<sub>0</sub> : Permissible maximum axial load

Fr : Radial force acting on the shaft

Fr<sub>0</sub> : Permissible maximum radial load at the end of the shaft

Fr<sub>max</sub> : Permissible maximum radial load at the shaft end

Permissible load calculations are based on a bearing life of L<sub>h10</sub> 20,000 hours according to ISO 281

## Axial Loads

VERTICAL MOUNTING - Shaft Up - Permissible Axial Loads  
Mounting Positions IM: V3, V6, V19, V35, V37

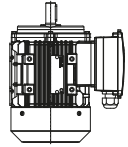

Frame Size	Push			Pull
	$Fr = 0$	$Fr = Fr_0$	$Fr = Fr_{max}$	$Fr = 0$
<b>2 Poles 3000 rpm</b>	<b><math>F_{a0}</math> [N]</b>	<b><math>F_{a0}</math> [N]</b>	<b><math>F_{a0}</math> [N]</b>	<b><math>F_{a0}</math> [N]</b>
63	90	90	90	230
71	100	100	100	265
80	170	170	170	425
90	180	180	180	450
<b>4 Poles 1500 rpm</b>	<b><math>F_{a0}</math> [N]</b>	<b><math>F_{a0}</math> [N]</b>	<b><math>F_{a0}</math> [N]</b>	<b><math>F_{a0}</math> [N]</b>
63	90	90	90	345
71	95	95	95	380
80	160	160	160	600
90	170	170	170	650

## Axial Loads

VERTICAL MOUNTING - Shaft Down - Permissible Axial Loads  
Mounting Positions IM: V1, V5, V15, V17, V18

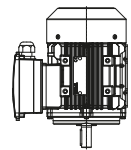

Frame Size	Push			Pull
	$Fr = 0$	$Fr = Fr_0$	$Fr = Fr_{max}$	$Fr = 0$
<b>2 Poles 3000 rpm</b>	<b><math>F_{a0}</math> [N]</b>	<b><math>F_{a0}</math> [N]</b>	<b><math>F_{a0}</math> [N]</b>	<b><math>F_{a0}</math> [N]</b>
63	110	110	110	210
71	130	130	130	235
80	220	220	220	385
90	250	250	250	375
<b>4 Poles 1500 rpm</b>	<b><math>F_{a0}</math> [N]</b>	<b><math>F_{a0}</math> [N]</b>	<b><math>F_{a0}</math> [N]</b>	<b><math>F_{a0}</math> [N]</b>
63	120	110	120	300
71	130	130	130	340
80	220	220	220	540
90	260	260	260	545

$F_{a0}$  : Permissible maximum axial load

$Fr$  : Radial force acting on the shaft

$Fr_0$  : Permissible maximum radial load at the end of the shaft

$Fr_{max}$  : Permissible maximum radial load at the shaft end

Permissible load calculations are based on a bearing life of Lh10 20,000 hours according to ISO 281.

## Product Type Codes of Single-Phase Motors

**2 MS 080 M 4 C PD M8 000**

2	----->	Motor Efficiency Class 2: IE2
MS	----->	Basic Motor Types MD : Single-Phase Motors with Run Capacitor MS : Single-Phase Motors with Start and Run Capacitor
080	----->	Frame Size: 63, 71, 80, 90 Height of the shaft axis from feet base of motor(mm)
M	----->	Housing Length S : Short M: Medium L : Long
4	----->	Number of Poles 2: 2 Poles 3000 rpm 4: 4 Poles 1500 rpm
C	----->	Core Length: A, B, C, D, E
PD	----->	Construction Types/Flange Types PD: B3 Foot Mounted FA: B5 Flange FB: B14/2 Flange PB: B14/2 Feet FC : B14 Flange FS : Special Flange PA : B35 PC : B34 PS :Foot mounted with special flange Y0..Y9 :With flange for gearbox connection PX : Foot mounted without drive end shield XX : Without foot and drive end shield Z0-Z9 : Foot mounted Yılmaz type
M8	----->	Electrical Specifications AA..ZZ Voltage, Frequency and Electrical features M8 : 230V 50Hz 70 : 220V 50Hz Y0: 220V 60Hz Y2: 230V 60Hz
000	----->	Additional Motor Features 000 : Standard Motor

**SINGLE-PHASE MOTORS**



**IE2**

**Motors**

# Electrical Characteristics

## Run Capacitor Motors

230V 50Hz 3000 rpm

Duty Cycle : S1 (Continuous Operation)  
 Insulation Class : F (155°C)  
 Temperature Rise : B (80°K)

**IE2**

Voltage (V)	Type	Rated Values									Starting Values		Break Down Torque	Run Capacitor Capacity	Moment of Inertia	B3 Motor Weight
		Power	Speed	Current	Torque	Power Factor	Efficiency % $\eta$			Current	Torque					
		kW	rpm	A	Nm	Cos $\phi$	4/4	3/4	1/2	I <sub>A</sub> /I <sub>N</sub>	M <sub>A</sub> /M <sub>N</sub>	M <sub>K</sub> /M <sub>N</sub>				
1~ 230V 50Hz	2MD063M2A	0,18	2785	1,25	0,62	0,98	64,0	61,0	55,2	3,00	0,60	1,90	10	0,00013	4,10	
	2MD063M2B	0,25	2820	1,68	0,85	0,97	67,0	63,1	57,1	3,30	0,65	2,00	15	0,00016	4,30	
	2MD071M2B	0,37	2840	2,20	1,24	0,98	74,4	73,0	64,5	3,70	0,60	1,90	20	0,00032	6,60	
	2MD071M2C	0,55	2845	3,18	1,85	0,98	76,5	75,2	68,0	3,80	0,60	2,00	25	0,00039	7,60	
	2MD080M2B	0,75	2800	4,31	2,56	0,98	77,4	74,4	67,3	3,80	0,60	2,10	30	0,00094	9,90	
	2MD080M2C	1,10	2810	6,05	3,74	0,99	79,6	78,6	73,0	3,80	0,57	2,10	40	0,00108	11,6	
	2MD090S2B	1,50	2810	8,20	5,10	0,98	81,3	81,2	76,0	4,00	0,52	2,00	60	0,00160	16,2	
	2MD090L2D	2,20	2850	11,8	7,37	0,98	83,2	82,0	75,7	4,40	0,52	2,10	80	0,00234	19,0	

230V 50Hz 1500 rpm

Duty Cycle : S1 (Continuous Operation)  
 Insulation Class : F (155°C)  
 Temperature Rise : B (80°K)

**IE2**

Voltage (V)	Type	Rated Values									Starting Values		Break Down Torque	Run Capacitor Capacity	Moment of Inertia	B3 Motor Weight
		Power	Speed	Current	Torque	Power Factor	Efficiency % $\eta$			Current	Torque					
		kW	rpm	A	Nm	Cos $\phi$	4/4	3/4	1/2	I <sub>A</sub> /I <sub>N</sub>	M <sub>A</sub> /M <sub>N</sub>	M <sub>K</sub> /M <sub>N</sub>				
1~ 230V 50Hz	2MD063M4B	0,12	1415	0,91	0,81	0,97	59,1	50,8	40,5	2,30	0,58	1,75	10	0,00019	4,40	
	2MD063M4C	0,18	1420	1,27	1,21	0,95	64,7	57,2	44,0	2,50	0,60	1,90	15	0,00023	5,00	
	2MD071M4C	0,25	1445	1,73	1,65	0,93	68,5	61,4	49,8	3,50	0,60	2,00	15	0,00071	7,40	
	2MD071M4D	0,37	1440	2,36	2,45	0,94	72,7	65,8	54,3	3,20	0,50	2,00	20	0,00086	8,20	
	2MD080M4C	0,55	1415	3,20	3,71	0,97	77,1	72,0	63,1	3,50	0,55	2,00	30	0,00184	10,6	
	2MD080M4D	0,75	1400	4,18	5,12	0,98	79,6	77,2	69,5	3,50	0,55	1,90	30	0,00210	12,4	
	2MD090S4D	1,10	1420	6,00	7,40	0,98	81,4	79,2	71,8	4,00	0,45	1,90	40	0,00295	18,1	
	2MD090L4E	1,50	1420	8,20	10,1	0,96	82,8	81,0	74,2	4,00	0,45	1,70	60	0,00373	18,7	

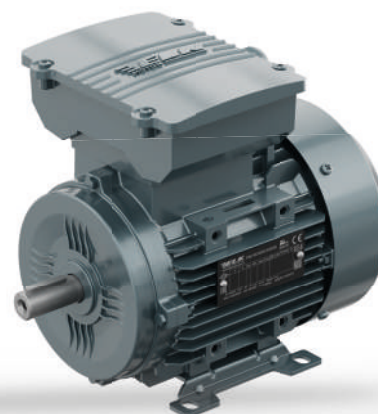

# Electrical Characteristics

## Run+Start Capacitor Motors

230V 50Hz 3000 rpm

Duty Cycle : S1 (Continuous Operation)

Insulation Class : F (155°C)

Temperature Rise : B (80°K)

**IE2**

Voltage (V)	Type	Rated Values							Starting Values			Break Down Torque	Capacitor		Moment of Inertia	B3 Motor Weight
		Power	Speed	Current	Torque	Power Factor	Efficiency % $\eta$			Current	Torque		Run	Start		
		kW	rpm	A	Nm	Cos $\phi$	4/4	3/4	1/2	I <sub>A</sub> /I <sub>N</sub>	M <sub>A</sub> /M <sub>N</sub>	M <sub>K</sub> /M <sub>N</sub>	$\mu$ F	$\mu$ F	kgm <sup>2</sup>	kg
1~ 230V 50Hz	2MS063M2A	0,18	2785	1,25	0,62	0,98	64,0	61,0	55,2	4,80	2,70	1,90	10	36-43	0,00013	4,30
	2MS063M2B	0,25	2820	1,68	0,85	0,97	67,0	63,1	57,1	4,90	2,80	2,00	15	43-52	0,00016	4,50
	2MS071M2B	0,37	2840	2,20	1,24	0,98	74,4	73,0	64,5	4,90	2,60	1,90	20	53-64	0,00032	6,80
	2MS071M2C	0,55	2845	3,18	1,85	0,98	76,5	75,2	68,0	4,90	2,60	2,00	25	72-86	0,00039	7,80
	2MS080M2B	0,75	2800	4,31	2,56	0,98	77,4	74,4	67,3	5,30	2,60	2,10	30	88-106	0,00094	10,1
	2MS080M2C	1,10	2810	6,05	3,74	0,99	79,6	78,6	73,0	5,30	2,70	2,10	40	145-174	0,00108	11,8
	2MS090S2B	1,50	2810	8,20	5,10	0,98	81,3	81,2	76,0	5,00	2,20	2,00	60	189-227	0,00160	16,4
	2MS090L2D	2,20	2850	11,8	7,37	0,98	83,2	82,0	75,7	4,80	1,50	2,10	80	161-193	0,00234	19,2

Duty Cycle : S1 (Continuous Operation)

Insulation Class : F (155°C)

Temperature Rise : B (80°K)

**IE2**

230V 50Hz 1500 rpm

Voltage (V)	Type	Rated Values							Starting Values			Break Down Torque	Capacitor		Moment of Inertia	B3 Motor Weight
		Power	Speed	Current	Torque	Power Factor	Efficiency % $\eta$			Current	Torque		Run	Start		
		kW	rpm	A	Nm	Cos $\phi$	4/4	3/4	1/2	I <sub>A</sub> /I <sub>N</sub>	M <sub>A</sub> /M <sub>N</sub>	M <sub>K</sub> /M <sub>N</sub>	$\mu$ F	$\mu$ F	kgm <sup>2</sup>	kg
1~ 230V 50Hz	2MS063M4B	0,12	1415	0,91	0,81	0,97	59,1	50,8	40,5	4,90	2,60	1,75	10	30-36	0,00019	4,60
	2MS063M4C	0,18	1420	1,27	1,21	0,95	64,7	57,2	44,0	4,80	2,70	1,90	15	30-36	0,00023	5,20
	2MS071M4C	0,25	1445	1,73	1,65	0,93	68,5	61,4	49,8	4,90	2,70	2,00	15	36-43	0,00071	7,60
	2MS071M4D	0,37	1440	2,36	2,45	0,94	72,7	65,8	54,3	4,70	2,50	2,00	20	53-64	0,00086	8,40
	2MS080M4C	0,55	1415	3,20	3,71	0,97	77,1	72,0	63,1	4,60	2,60	2,00	30	64-77	0,00184	10,8
	2MS080M4D	0,75	1400	4,18	5,12	0,98	79,6	77,2	69,5	4,50	2,60	1,90	30	72-86	0,00210	12,6
	2MS090S4D	1,10	1420	6,00	7,40	0,98	81,4	79,2	71,8	5,10	2,60	1,90	40	145-174	0,00295	18,3
	2MS090L4E	1,50	1420	8,20	10,1	0,96	82,8	81,0	74,2	4,50	2,10	1,70	60	161-193	0,00373	18,9

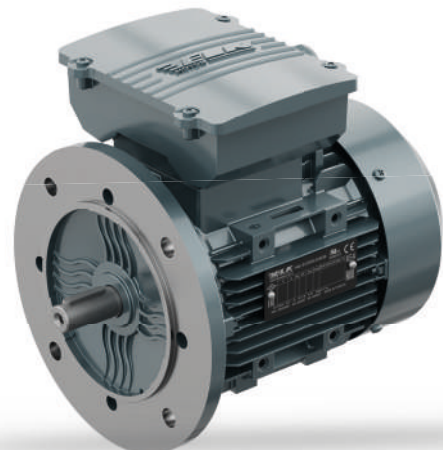

**SINGLE-PHASE MOTORS**



**Dimensions**

# Single Phase Motors

# B3 Construction Type

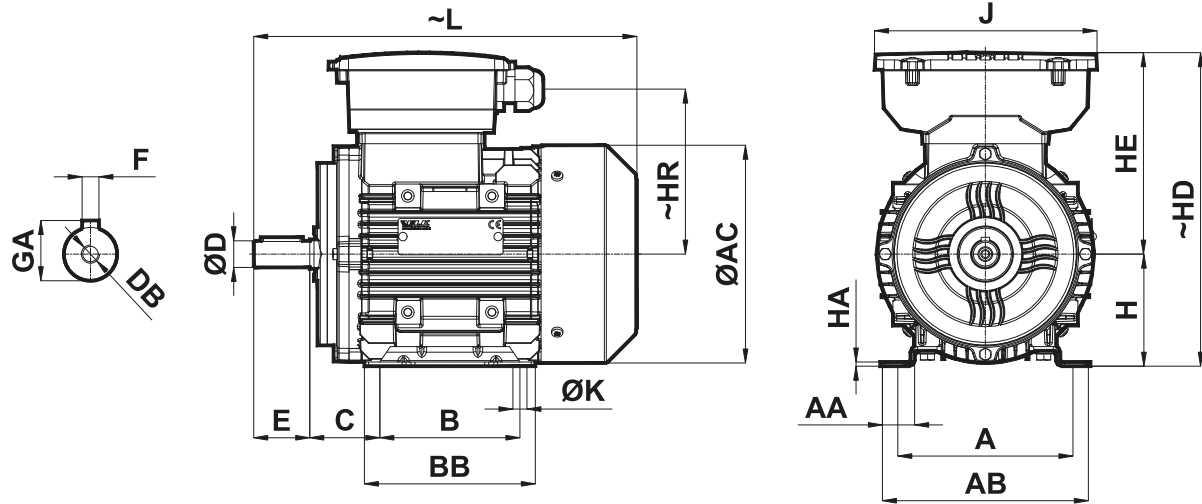

Frame Size	No. of Poles	D <sup>[1]</sup>	E	L	AC	HR	H <sup>[2]</sup>	HE	HD	F	GA	DB	C	ØK	B	BB	HA	AA	A	AB	J
063M	2-4	11	23	213	119	92	63	128	191	4	12,5	M4	40	7	80	104	3	18	100	115	153
071M	2-4	14	30	242	137	108	71	135	206	5	16	M5	45	7	90	110	3	19	112	128	159
080M	2-4	19	40	274	155	117	80	144	224	6	21,5	M6	50	10	100	122	3	25	125	148	159
090S	2-4	24	50	325	176	133	90	170	260	8	27	M8	56	10	125	151	4	27	140	167	173
090L	2-4	24	50	325	176	133	90	170	260	8	27	M8	56	10	125	151	4	27	140	167	173

[1] Tolerance "j6" TS EN 50347

[2] Tolerance "-0.5mm" TS EN 50347

# B14 - B34 Construction Types

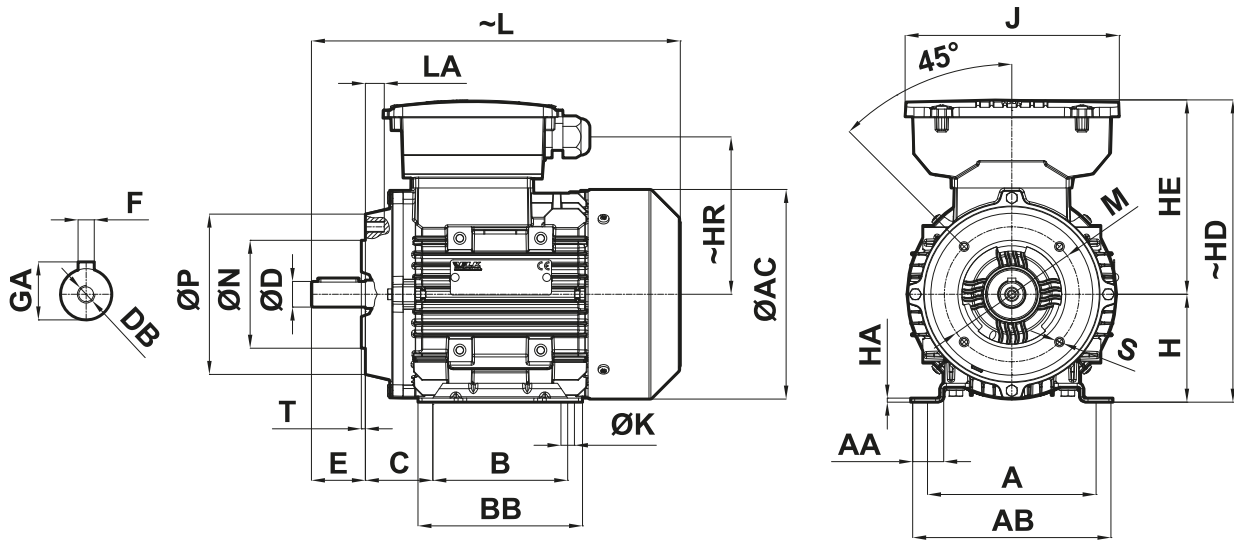

Frame Size	No. of Poles	D <sup>[1]</sup>	N <sup>[2]</sup>	P	E	T	LA	L	AC	S	M	HR	H <sup>[3]</sup>	HE	HD	F	GA	DB	C	ØK	B	BB	HA	AA	A	AB	J
063M	2-4	11	60	90	23	2,5	10	213	119	M5	75	92	63	128	191	4	12,5	M4	40	7	80	104	3	18	100	115	153
071M	2-4	14	70	105	30	2,5	12	242	137	M6	85	108	71	135	206	5	16	M5	45	7	90	110	3	19	112	128	159
080M	2-4	19	80	119	40	3	12	274	155	M6	100	117	80	144	224	6	21,5	M6	50	10	100	122	3	25	125	148	159
090S	2-4	24	95	137	50	3	15	325	176	M8	115	133	90	170	260	8	27	M8	56	10	125	151	4	27	140	167	173
090L	2-4	24	95	137	50	3	15	325	176	M8	115	133	90	170	260	8	27	M8	56	10	125	151	4	27	140	167	173

[1] Tolerance "j6" TS EN 50347

[2] Tolerance "j6" TS EN 50347

[3] Tolerance "-0.5mm" TS EN 50347

# Single Phase Motors

# B5 – B35 Construction Types

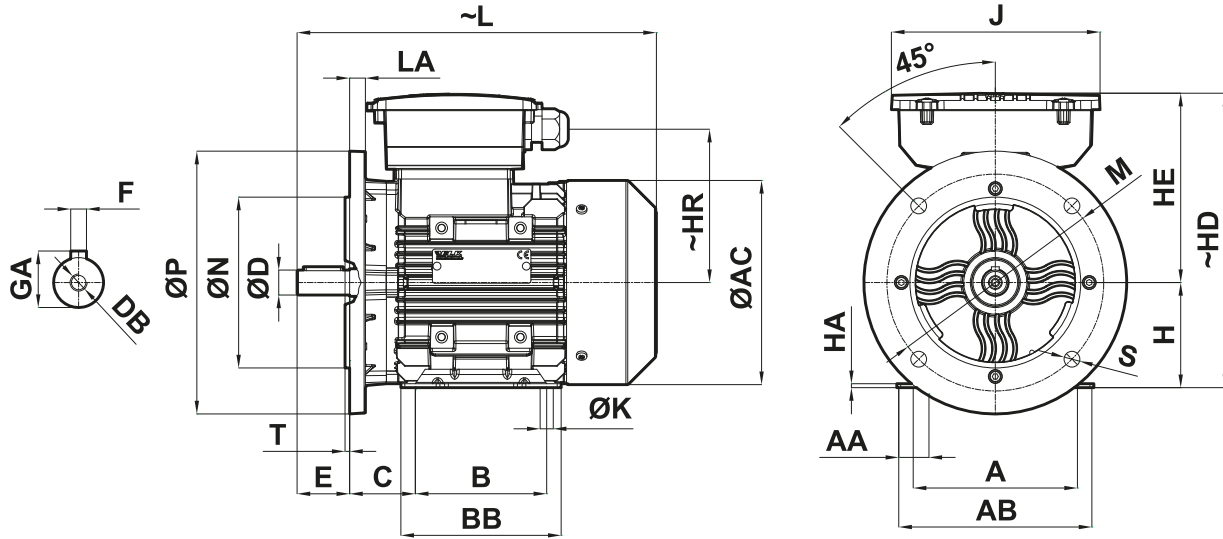

Frame Size	No. of Poles	D <sup>[1]</sup>	E	N <sup>[2]</sup>	P	T	LA	L	AC	S	M	HR	H <sup>[3]</sup>	HE	HD	F	GA	DB	C	$\varnothing K$	B	BB	HA	AA	A	AB	J
063M	2-4	11	23	95	140	3,0	8	213	119	10	115	92	63	128	191	4	12,5	M4	40	7	80	104	3	18	100	115	153
071M	2-4	14	30	110	160	3,5	8	242	137	10	130	108	71	135	206	5	16	M5	45	7	90	110	3	19	112	128	159
080M	2-4	19	40	130	200	3,5	12	274	155	12	165	117	80	144	224	6	21,5	M6	50	10	100	122	3	25	125	148	159
090S	2-4	24	50	130	200	3,5	12	325	176	12	165	133	90	170	260	8	27	M8	56	10	125	151	4	27	140	167	173
090L	2-4	24	50	130	200	3,5	12	325	176	12	165	133	90	170	260	8	27	M8	56	10	125	151	4	27	140	167	173

[1] Tolerance "j6" TS EN 50347

[2] Tolerance "j6" TS EN 50347

[3] Tolerance "-0.5mm" TS EN 50347

## Motor Nameplate Example

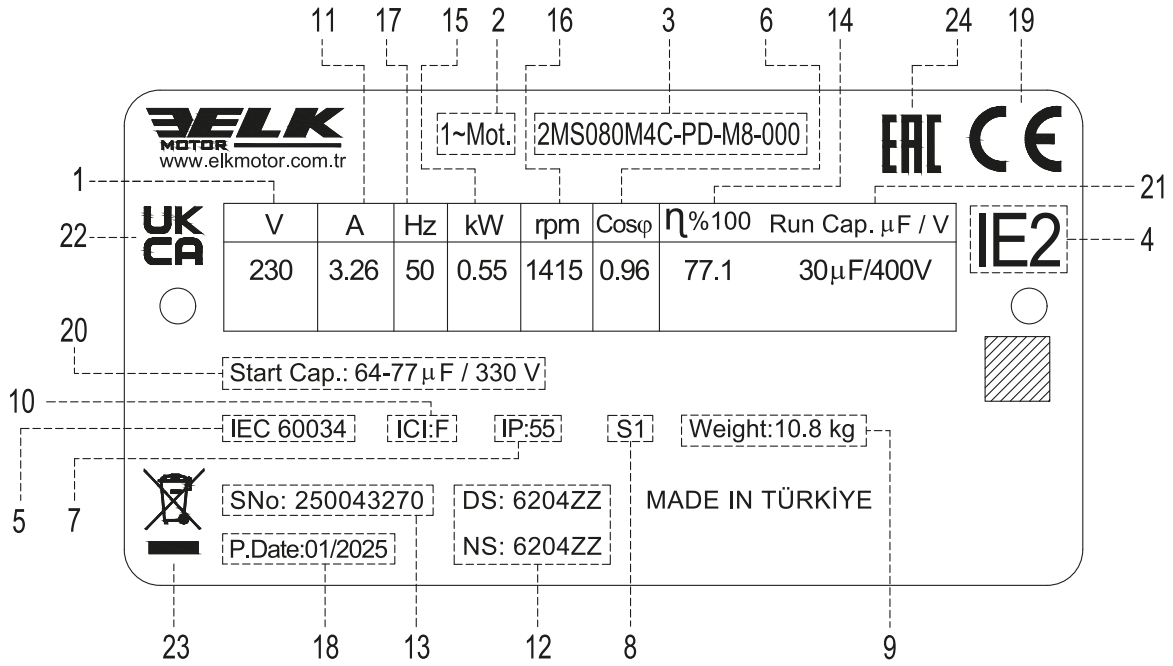

1. Rated Voltage	13. Serial Number
2. Motor Type: Single Phase Motor	14. Efficiency
3. Motor Code	15. Output Power
4. Efficiency Class	16. Speed
5. Manufacture Standard	17. Frequency
6. Power Factor	18. Production Date
7. Protection Class	19. CE Logo
8. Duty Cycle	20. Start Capacitor Specifications
9. Motor Weight	21. Run Capacitor Specifications
10. Insulation Class	22. UKCA Logo
11. Rated Current	23. WEEE Symbol
12. Bearing Type	24. EAC Logo



The nameplate shows the identification, and the most important technical data. The nameplate also defines the limits of proper usage, and manufacturing year of the motors. The first two digits in the serial number, shows the manufacturing year. For example, 25XXXXXXXX shows that the product is manufactured in 2025.

# Single-Phase Motor with Run Capacitor Spare Parts

All standard single-phase run capacitor motors manufactured by ELK MOTOR consist of the following main components:

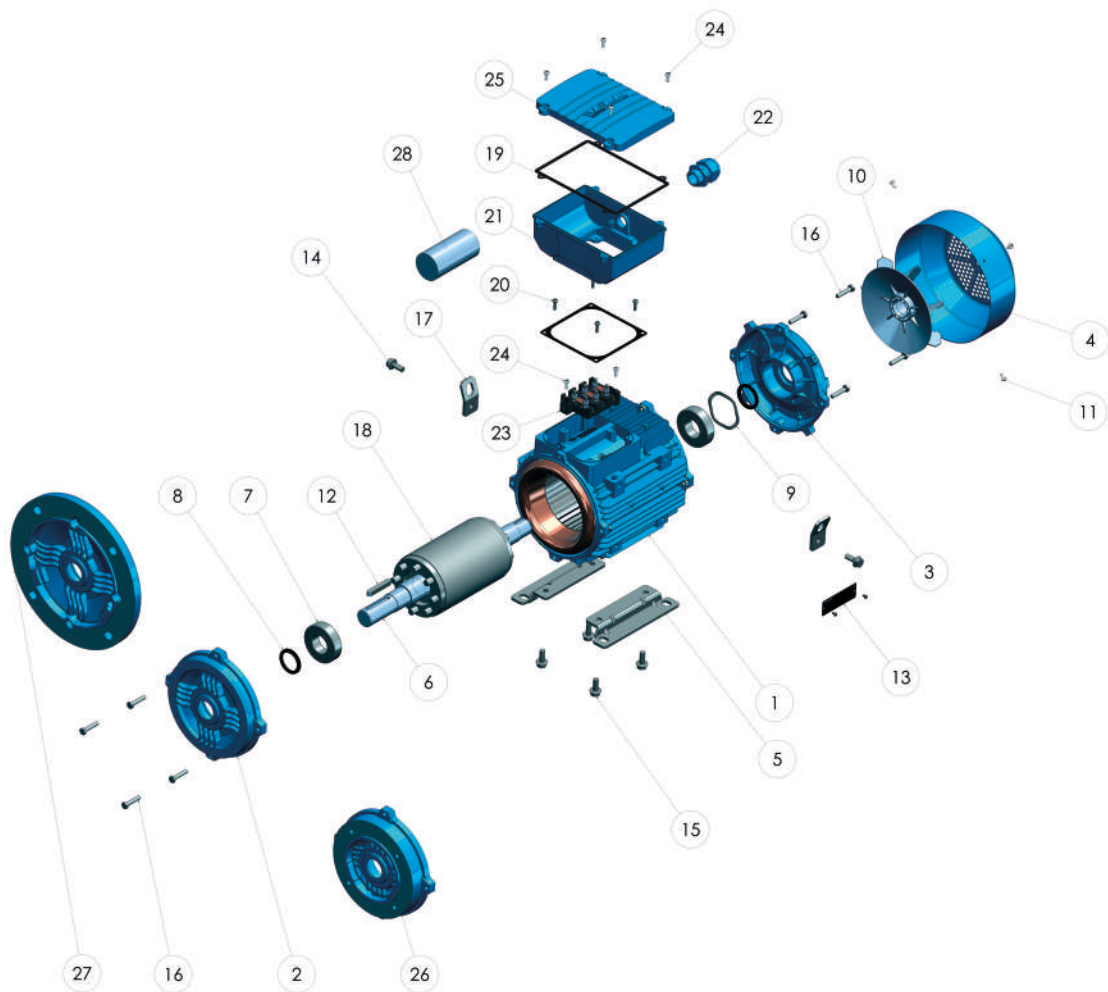

1.	Housing
2.	End Shield (DE)
3.	End Shield (NDE)
4.	Fan Cover
5.	Mounting Foot
6.	Shaft
7.	Bearing
8.	Shaft Seal
9.	Spring Washer
10.	Fan
11.	Screw
12.	Key
13.	Nameplate
14.	Screw

15.	Screw
16.	Bolt
17.	Lifting Lug
18.	Squirrel Cage Rotor
19.	Terminal Box Gasket
20.	Screw
21.	Terminal Box
22.	Cable Gland
23.	Terminal
24.	Screw
25.	Terminal Box Cover
26.	B14 Flange
27.	B5 Flange
28.	Run Capacitor

When ordering spare parts, the motor serial number, full type designation, and product code, as stated on the nameplate, must be specified. For field service, spare parts and additional information, please contact with us.

# Single-Phase Motor with Run + Start Capacitors Spare Parts

All standard single-phase run and start capacitor motors manufactured by ELK MOTOR consist of the following main components:

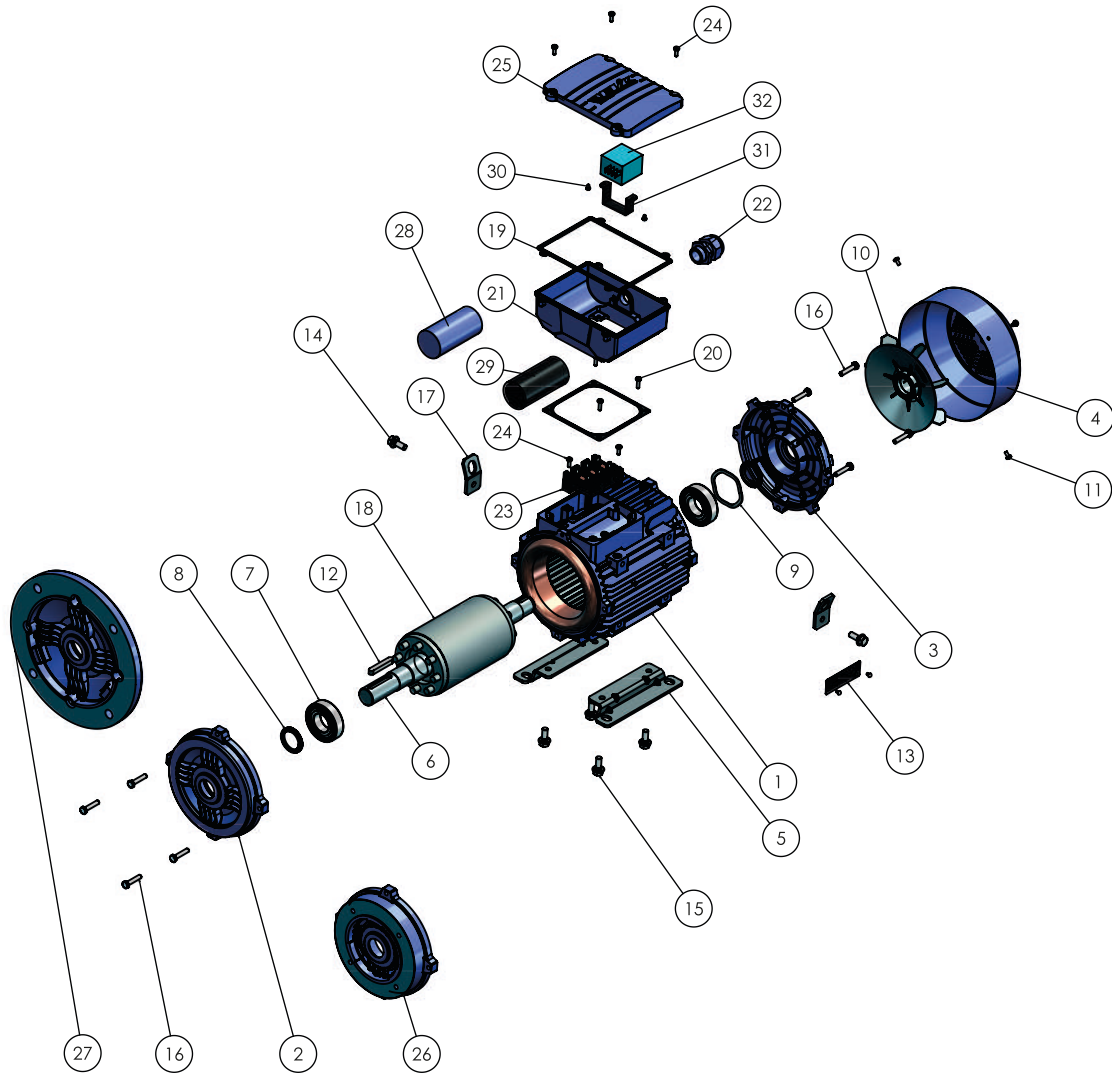

- |                     |                                      |
|---------------------|--------------------------------------|
| 1. Housing          | 17. Lifting Lug                      |
| 2. End Shield (DE)  | 18. Squirrel Cage Rotor              |
| 3. End Shield (NDE) | 19. Terminal Box Gasket              |
| 4. Fan Cover        | 20. Screw                            |
| 5. Mounting Foot    | 21. Terminal Box                     |
| 6. Shaft            | 22. Cable Gland                      |
| 7. Bearing          | 23. Terminal                         |
| 8. Shaft Seal       | 24. Screw                            |
| 9. Spring Washer    | 25. Terminal Box Cover               |
| 10. Fan             | 26. B14 Flange                       |
| 11. Screw           | 27. B5 Flange                        |
| 12. Key             | 28. Run Capacitor                    |
| 13. Nameplate       | 29. Start Capacitor                  |
| 14. Screw           | 30. Screw                            |
| 15. Screw           | 31. Starter Relay Mounting Apparatus |
| 16. Bolt            | 32. Starter Relay                    |

While ordering spare parts, the motor serial number, full type designation and product code, as stated on the nameplate, must be specified. For field service, spare parts and additional information, please contact us.

**EXPROOF MOTORS**



**Technical Information**

## Overview

Electrical equipment and devices can pose risks to the environment and human health when they come into contact with flammable and explosive substances such as fumes, dust, and smoke present in the surroundings. To ensure maximum safety, international ATEX regulations and standards have been implemented to define the essential health and safety requirements and conformity assessment procedures for equipment and protective systems used in potentially explosive environments. Exproof equipment is designed to prevent explosions when used correctly. These devices can be designed to meet various protection types. The types of protection and areas are determined based on the likelihood of the presence of a potentially explosive atmosphere. Equipment categories are assigned to these areas, which are then subdivided into potential protection types and thus into potential equipment (product) types. Depending on the specific area and related hazard, operational equipment must comply with the minimum requirements specified for the protection type. Different protection types require specific measures to prevent ignition and ensure safety in environments with explosive atmospheres.

## Typical Applications

Oil and Gas Industry  
 Chemical industry  
 Pharmaceutical industry  
 Oil and petrochemical plants  
 Food and Beverage Industry  
 Paint and Coating Industry  
 Natural gas facilities  
 Wastewater Treatment Plants  
 Iron-steel industry

*\*Proper motor selection according to the application's needs is the responsibility of the application/system engineer.*

## IEC/EN Compatibility

All of standard ELK Motors are designed, manufactured and tested according to the IEC and EN standards given below.



IEC 60079-0	General Terms	} Explosive atmospheres
IEC 60079-7	Increased Safety "e"	
IEC 60079-1	Equipment Protection by Flameproof Enclosures "d"	
IEC 60079-31	Equipment Dust Ignition Protection by Enclosure "t"	
IEC 60034-1	Rating and Performance	
IEC 60034-2-1	Determining Losses and Efficiency From Tests	
IEC 60034-5	Protection Degree Classification (IP)	
IEC 60034-6	Cooling Methods	
IEC 60034-7	Classification of Construction Types and Mounting Arrangements	
IEC 60034-8	Terminal Markings and Direction of Rotation	
IEC 60034-9	Noise Limits	
IEC 60034-11	Thermal Protection	
IEC 60034-14	Mesurement, Evaluation and Limits of Vibration Severity	
IEC 60034-18-1	Functional evolution of Insulation System	
IEC 60034-30	Efficiency Classes (IE Code)	
IEC 60038	Standard Voltages	
EN 50347	Standart Dimensions and Output Powers	
EN 55014-1	} Electromagnetic Compatibility	
EN 61000-3-2		
EN 61000-3-3		

Our products may deviate from the nominal values stated in our catalog within the limits of the tolerances permitted by IEC 60034-1, as specified below,

<b>Motor Speed (n)</b>	$\Delta n = \pm 20\% (n_s - n_N), P_N \Rightarrow 1 \text{ kW}$ $\Delta n = \pm 30\% (n_s - n_N), P_N < 1 \text{ kW}$
<b>Efficiency %(<math>\eta</math>)</b>	$\Delta \eta = -15\% (100 - \eta_N)$
<b>Power factor (<math>\varphi</math>)</b>	$\text{Cos } \varphi = -1/6 (1 - \text{Cos } \varphi)$
<b>Locked rotor current (<math>I_{L,N}</math>)</b>	$\Delta (I_{L,N}) = +20\% (I_{L,N})$
<b>Starting torque (<math>M_L/M_N</math>)</b>	min. $(M_L/M_N) = -15\% (M_L/M_N)$ max. $(M_L/M_N) = +25\% (M_L/M_N)$
<b>Breakdown torque (<math>M_K/M_N</math>)</b>	$(M_K/M_N) = -10\% (M_K/M_N)$
<b>Moment of inertia (J) [kgm<sup>2</sup>]</b>	$\Delta J = \pm 10\% J$
<b>Sound pressure level (<math>L_{PA}</math>) [dB(A)]</b>	$L_{PA} = +3 \text{ dB (A)}$

## Explosive Atmospheres Protection Directive 2014/34/EU

Explosion protection has been fully aligned with Directive 2014/34/EU. The requirements of the new regulation came into effect on April 20, 2016. Since that date, only devices and protection systems compliant with Directive 2014/34/EU are permitted to be placed on the market. Directive 2014/34/EU and Directive 1999/92/EC specify that only certain electrical equipment and devices are permitted in designated zones. Devices are assigned to equipment groups and categories.

Example Increased Protection		2284		II	3	G	Ex	ec	IIC	T4	Gc
CE marking				II	3	D	Ex	tc	IIIC	T120 °C - T140 °C	Dc
Notified Body Number											
Symbol for Explosion Protection											
Equipment Group	I: Mining II: Non-mining										
Equipment Category	2: Zone 1/21 3: Zone 2/22										
Environment	G: Gas D: Dust										
Explosion Protection											
Type of Protection	Ex db, db eb, eb, ec, tb veya tc										
Environment Sub Category	II: Gas (IIA, IIB veya IIC) III: Dust (IIIA, IIIB veya IIIC)										
Temperature Class (Maximum Surface Temperature)	T1 = 450 °C    T4 = 135 °C T2 = 300 °C    T5 = 100 °C T3 = 200 °C    T6 = 85 °C										

Equipment Protection Level (G: Gas - D: Dust)

Ga: Very High Protection	Da: Very High Protection
Gb: High Protection	Db: High Protection
Gc: Enhanced Protection	Dc: Enhanced Protection

# Electrical Construction

Our Exproof motors feature an F-class (155°C) Insulation Class. Additionally, all Ex motors in our product range remain within the B-class Temperature Rise limits.

## Electrical Connections

Exproof Motor Cable Gland Informations															
Frame Size	063	071	080	090	100	112	132	160	180	200	225	250	280	315	
Zone 1/21 Cable Glands	-	-			2 x M25x1,5 1 x M12x1,5			2 x M40x1,5 1 x M12x1,5		2 x M40x1,5 1 x M12x1,5		2 x M50x1,5 1 x M12x1,5		2 x M63x1,5 1 x M12x1,5	-
Zone 2/22 Cable Glands	2 x M16x1,5		1 x M20x1,5 1 x M16x1,5		1 x M25x1,5 1 x M20x1,5			2 x M32x1,5		2 x M40x1,5 1 x M12x1,5		2 x M50x1,5 1 x M12x1,5		2 x M63x1,5	

The cable glands are Ex-certified and unarmored. They can be provided with armor upon request.

Exproof Motor Terminal Connections														
Frame Size	063	071	080	090	100	112	132	160	180	200	225	250	280	315
Zone 1/21 Terminal Size	-				M5			M6			M8	M10		-
Zone 2/22 Terminal Size	M4				M5			M6			M8	M10		M16

Three-phase EX motors should be connected in either star or delta configuration, depending on the voltage specified on the motor nameplate and the supply voltage. Motors with a 230/400V nameplate should be connected in star configuration, while motors with a 400/690V nameplate should be connected in delta configuration on a 400V network. Star-Delta starting is applicable to 400/690V motors when operated on a 400V supply network. The terminal connections for three-phase motors are provided below.

### Terminal Connections for Three-Phase Motors

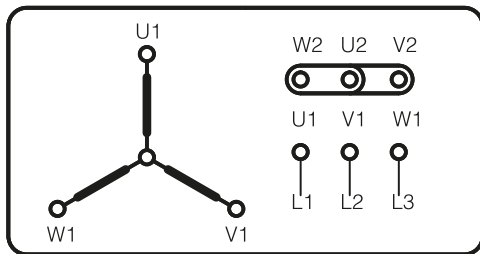

**Y** Star Connection  
Clockwise Rotation

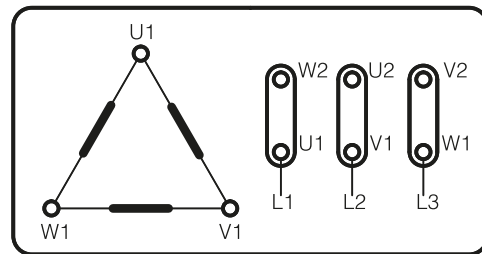

**Δ** Delta Connection  
Clockwise Rotation

Standard ELK motors are manufactured to rotate clockwise. To change the direction of rotation, the positions of any two phases on the terminal can be swapped. For an illustrative example, refer to the schematic below.

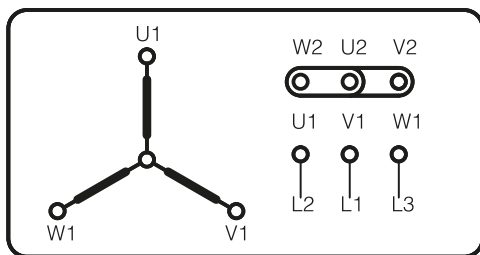

**Y** Star Connection  
Counter-clockwise Rotation

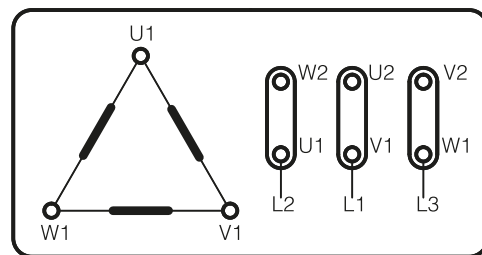

**Δ** Delta Connection  
Counter-clockwise Rotation

# Winding Insulation / Temperature Rise Classes

INSULATION CLASS

Maximum Winding Temperature

Tolerance

Limits of Winding Temperature

Ambient Temperature

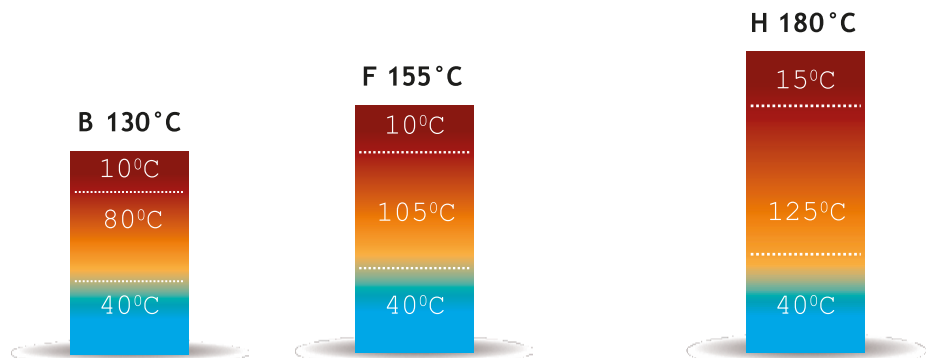

## B (Out of production)

Class B insulation system is shown for reference purposes only. Class B insulation system is not used in ELK motors.

## F (Standard)

Our standard motors have class F electrical insulation system. The maximum permissible winding temperature at 40°C ambient temperature is 155°C.

## H (Optional)

H class insulation is provided on special request. At 40°C ambient temperature, the maximum permissible winding temperature is 180°C

## Protection Classes

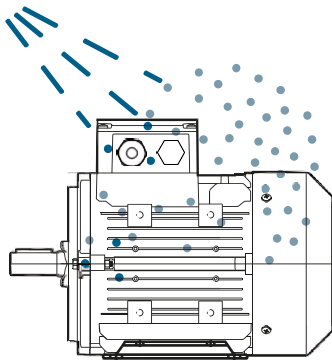

### IP55

Limited protection against dust ingress and protected against low pressure water jets from any direction.

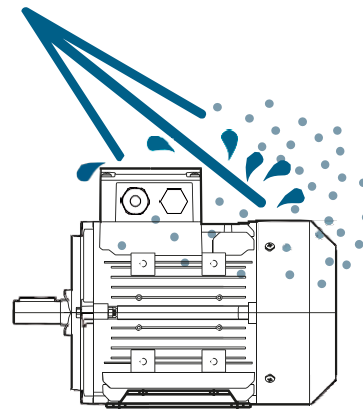

### IP56

Limited protection against dust ingress and protected against high pressure water jets from any direction.

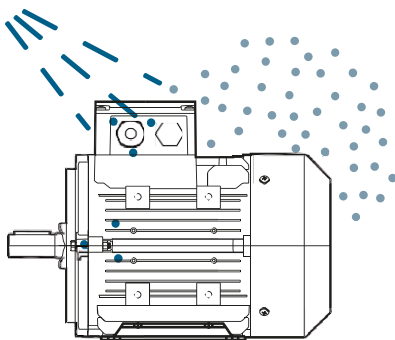

### IP65

Totally protected against dust ingress and protected against low pressure water jets from any direction.

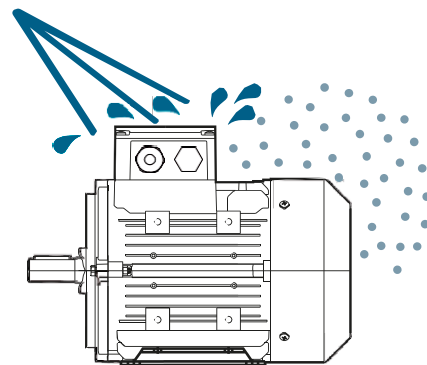

### IP66 (Standard)

Totally protected against dust ingress and protected against high pressure water jets from any direction.

## Zone 2/22 Mechanical Construction

Exproof ELK motors feature a removable foot structure for all frame sizes, with the feet capable of being attached to three sides of the frame. This allows users to adjust the foot position to easily configure the terminal box to be on the right, top, or left side of the motor. In standard motors, the terminal box is positioned at the top.

### FRAME SIZE 63-315

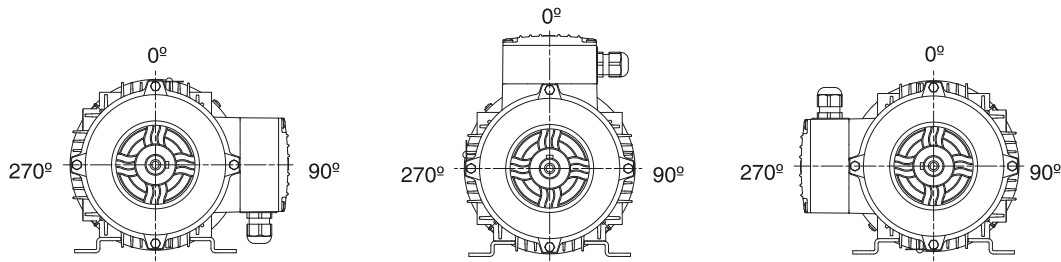

Additionally, Exproof ELK motors, thanks to their symmetrical frame and foot design, maintain a constant C dimension when the DE end-shield, NDE end-shield, and shaft direction are changed. This allows the terminal box to be positioned either close to the DE side or close to the NDE (fan) side.

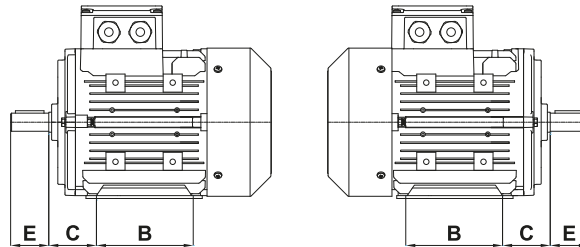

The raw materials that are used in our motors depending on the frame size are listed below.

Frame Size	Housing	End Shield DE	End Shield NDE	Terminal Box & Cover	Feet	Fan Cover	Fan*
63	Aluminum	Aluminum	Aluminum	Aluminum	Steel Sheet	Steel Sheet	Plastic
71	Aluminum	Aluminum	Aluminum	Aluminum	Steel Sheet	Steel Sheet	Plastic
80	Aluminum	Aluminum	Aluminum	Aluminum	Steel Sheet	Steel Sheet	Plastic
90	Aluminum	Aluminum	Aluminum	Aluminum	Steel Sheet	Steel Sheet	Plastic
100	Aluminum	Aluminum	Aluminum	Aluminum	Steel Sheet	Steel Sheet	Plastic
112	Aluminum	Aluminum	Aluminum	Aluminum	Steel Sheet	Steel Sheet	Plastic
132	Aluminum	Aluminum	Aluminum	Aluminum	Steel Sheet	Steel Sheet	Plastic
	Cast Iron	Cast Iron	Cast Iron	Cast Iron	Cast Iron	Steel Sheet	Plastic
160	Aluminum	Aluminum	Aluminum	Aluminum	Aluminum	Steel Sheet	Plastic
	Cast Iron	Cast Iron	Cast Iron	Cast Iron	Cast Iron	Steel Sheet	Plastic
180	Aluminum	Aluminum	Aluminum	Aluminum	Aluminum	Steel Sheet	Plastic
	Cast Iron	Cast Iron	Cast Iron	Cast Iron	Cast Iron	Steel Sheet	Plastic
200	Aluminum	Aluminum	Aluminum	Aluminum	Aluminum	Steel Sheet	Plastic
	Cast Iron	Cast Iron	Cast Iron	Cast Iron	Cast Iron	Steel Sheet	Plastic
225	Aluminum	Aluminum	Aluminum	Aluminum	Aluminum	Steel Sheet	Plastic
	Cast Iron	Cast Iron	Cast Iron	Cast Iron	Cast Iron	Steel Sheet	Plastic
250	Aluminum	Aluminum	Aluminum	Aluminum	Aluminum	Steel Sheet	Plastic
	Cast Iron	Cast Iron	Cast Iron	Cast Iron	Cast Iron	Steel Sheet	Plastic
280	Cast Iron	Cast Iron	Cast Iron	Cast Iron	Cast Iron	Steel Sheet	Plastic
315	Cast Iron	Cast Iron	Cast Iron	Cast Iron	Cast Iron	Steel Sheet	Plastic

The fan material is flame retardant (V0), antistatic, and halogen-free, in compliance with the relevant standards.

## Zone 1/21 Mechanical Construction

Exproof ELK motors feature a removable foot structure for all frame sizes, with the feet capable of being attached to three sides of the frame. This allows users to adjust the foot position to easily configure the terminal box to be on the right, top, or left side of the motor. In standard motors, the terminal box is positioned at the top.

### FRAME SIZE 100-280

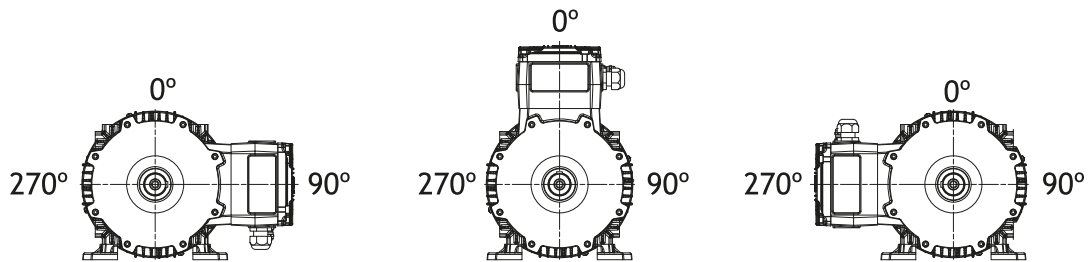

Additionally, Exproof ELK motors, thanks to their symmetrical frame and foot design, maintain a constant C dimension when the DE end-shield, NDE end-shield, and shaft direction are changed. This allows the terminal box to be positioned either close to the DE side or close to the NDE (fan) side.

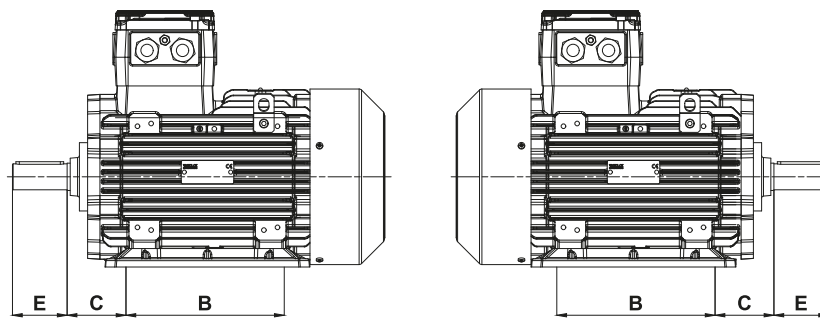

The raw materials that are used in our motors depending on the frame size are listed below.

Frame Size	Housing	End Shield DE	End Shield NDE	Terminal Box & Cover	Feet	Fan Cover	Fan
100	Cast Iron	Cast Iron	Cast Iron	Cast Iron	Cast Iron	Cast Iron	Aluminum
112	Cast Iron	Cast Iron	Cast Iron	Cast Iron	Cast Iron	Cast Iron	Aluminum
132	Cast Iron	Cast Iron	Cast Iron	Cast Iron	Cast Iron	Cast Iron	Aluminum
160	Cast Iron	Cast Iron	Cast Iron	Cast Iron	Cast Iron	Cast Iron	Aluminum
180	Cast Iron	Cast Iron	Cast Iron	Cast Iron	Cast Iron	Cast Iron	Aluminum
200	Cast Iron	Cast Iron	Cast Iron	Cast Iron	Cast Iron	Cast Iron	Aluminum
225	Cast Iron	Cast Iron	Cast Iron	Cast Iron	Cast Iron	Cast Iron	Aluminum
250	Cast Iron	Cast Iron	Cast Iron	Cast Iron	Cast Iron	Cast Iron	Aluminum
280	Cast Iron	Cast Iron	Cast Iron	Cast Iron	Cast Iron	Cast Iron	Aluminum

\* For Zone 1/21 and Zone 22 construction types, see pages 16 and 17.

## Zone 2/22 Bearings

Ex ELK motors use the deep groove ball bearings specified in the table. Cylindrical roller bearings (NUP) are optional.

Frame Size	Number of Poles	End Shield DE	End Shield NDE
63	2-4-6-8	6201 ZZ C3	6201 ZZ C3
71	2-4-6-8	6202 ZZ C3	6202 ZZ C3
80	2-4-6-8	6204 ZZ C3	6204 ZZ C3
90	2-4-6-8	6205 ZZ C3	6205 ZZ C3
100	2-4-6-8	6206 ZZ C3	6206 ZZ C3
112	2-4-6-8	6206 ZZ C3	6206 ZZ C3
132	2-4-6-8	6208 ZZ C3	6208 ZZ C3
160	2-4-6-8	6309 ZZ C3	6209 ZZ C3
180	2-4-6-8	6310 ZZ C3	6210 ZZ C3
200	2-4-6-8	6312 ZZ C3	6212 ZZ C3
225	2-4-6-8	6313 ZZ C3	6213 ZZ C3
250	2-4-6-8	6315 ZZ C3	6215 ZZ C3
280	2	6315 C3	6315 C3
	4-6-8	6317 C3	6317 C3
315	2	6316 C3	6316 C3
	4-6-8	6319 C3	6319 C3

### Zone 2/22 Bearing Sensors

Optional sensor applications are available in 250, 280, and 315 frame motors to measure the bearing temperature (PT100) and vibration (SPM) values.

### Zone 2/22 Shaft Seals

The shaft seals specified in the table are used in Ex ELK Motors.

Frame Size	Number of Poles	Drive End Shaft Seal	Non-Drive End Shaft Seal
63	2-4-6-8	Ø12xØ24x4,5	Ø12xØ24x4,5
71	2-4-6-8	Ø15xØ30x4,5	Ø15xØ30x4,5
80	2-4-6-8	Ø20xØ30x4,5	Ø20xØ30x4,5
90	2-4-6-8	Ø25xØ35x5	Ø25xØ35x5
100	2-4-6-8	Ø30xØ40x5	Ø30xØ40x5
112	2-4-6-8	Ø30xØ40x5	Ø30xØ40x5
132	2-4-6-8	Ø40xØ52x5	Ø40xØ52x5
160	2-4-6-8	Ø45xØ72x6	Ø45xØ72x6
180	2-4-6-8	Ø50xØ72x8	Ø50xØ72x8
200	2-4-6-8	Ø60xØ90x10	Ø60xØ90x10
225	2-4-6-8	Ø65xØ80x10	Ø65xØ80x10
250	2-4-6-8	Ø75xØ90x10	Ø75xØ90x10
280	2	Ø75xØ115x12	Ø75xØ115x12
	4-6-8	Ø85xØ105x10	Ø85xØ105x10
315	2	Ø80xØ105x12	Ø80xØ105x12
	4-6-8	Ø95xØ120x10	Ø95xØ120x10

## Zone 1/21 Bearings

Ex ELK motors use the deep groove ball bearings specified in the table. For frame sizes between 160 and 280, cylindrical roller bearings (NUP type) are optional.

Frame Size	Number of Poles	End Shield DE	End Shield NDE
100	2-4-6	6306 ZZ C3	6306 ZZ C3
112	2-4-6	6306 ZZ C3	6306 ZZ C3
132	2-4-6	6308 ZZ C3	6308 ZZ C3
160	2-4-6	6309 ZZ C3	6309 ZZ C3
180	2-4-6	6310 ZZ C3	6310 ZZ C3
200	2-4-6	6312 ZZ C3	6312 ZZ C3
225	2-4-6	6313 ZZ C3	6313 ZZ C3
250	2-4-6	6315 ZZ C3	6315 ZZ C3
280	2 4-6-8	6315 C3 6317 C3	6315 C3 6317 C3

## Zone 1/21 Shaft Seals

The shaft seals specified in the table are used in Ex ELK Motors.

Frame Size	Number of Poles	Drive End Shaft Seal	Non-Drive End Shaft Seal
100	2-4-6-8	Ø30xØ40x5	Ø30xØ40x5
112	2-4-6-8	Ø30xØ40x5	Ø30xØ40x5
132	2-4-6-8	Ø40xØ52x5	Ø40xØ52x5
160	2-4-6-8	Ø45xØ72x6	Ø45xØ72x6
180	2-4-6-8	Ø50xØ72x8	Ø50xØ72x8
200	2-4-6-8	Ø60xØ90x10	Ø60xØ90x10
225	2-4-6-8	Ø65xØ80x10	Ø65xØ80x10
250	2-4-6-8	Ø75xØ90x10	Ø75xØ90x10
280	2 4-6-8	Ø75xØ90x10 Ø85xØ105x10	Ø75xØ90x10 Ø85xØ105x10

## Radial Loads

Radial Load on the Shaft (FR):

The radial load on the shaft can be calculated using the formula below.  
The calculated radial load must not exceed the permissible values specified in the tables ( $FR < Fr_x$ ). If it does, please consult us.

$$F_R = k \cdot \frac{P}{D \cdot n} \cdot 10^7 (N)$$

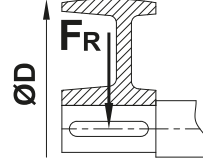

Correction of the Permissible Radial Load ( $Fr_x$ ):

If the radial load acting on the shaft is between points  $x_0$  and  $x_{max}$ , the permissible value should be corrected using the following formula.

$$Fr_x = Fr_0 - \frac{x}{E} (Fr_0 - Fr_{max})$$

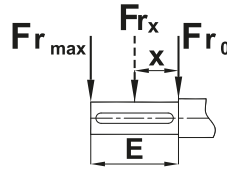

P: Motor Power (kW)  
D: Shaft Diameter (mm)  
n: Motor Speed (rpm)  
k: Radial Load Factor

- Spur Gears, chain drives with low speed = 2.1
- Trigger Belts = 2.5
- V type belts = 5

$FR < Fr_x$  : The radial load on the shaft must be less than the permissible maximum radial load.

Fa: Axial load acting on the shaft.

Fr0: Permissible maximum radial load on the shaft.

Fr max: Permissible maximum radial load at the end of the shaft.

Permissible load calculations are based on bearing lifetimes according to ISO 281, with an Lh10 of 20,000 hours.

## Zone 1/21 Radial Loads

HORIZONTAL MOUNTING - Permissible Radial Loads  
 Mounting Positions IM: B3, B5, B6, B7, B8, B14, B34, B35

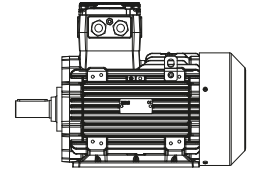

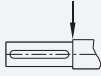
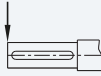
Frame Size	Fa = 0	
		
<b>2 Poles 3000 rpm</b>	<b>Fr<sub>0</sub> [N]</b>	<b>Fr<sub>max</sub> [N]</b>
100	1500	1250
112	1450	1220
132	2150	1780
160	2670	2150
180	3210	2630
200	4200	3450
225	4720	4010
250	5810	4750
280	6700	5200
<b>4 Poles 1500 rpm</b>	<b>Fr<sub>0</sub> [N]</b>	<b>Fr<sub>max</sub> [N]</b>
100	1900	1580
112	1870	1550
132	2750	2250
160	3350	2710
180	4020	3320
200	5250	4350
225	5910	4830
250	7250	5950
280	8700	7400
<b>6 Poles 1000 rpm</b>	<b>Fr<sub>0</sub> [N]</b>	<b>Fr<sub>max</sub> [N]</b>
100	2170	1810
112	2100	1800
132	3100	2550
160	3860	3120
180	4650	3840
200	6100	5050
225	6840	5580
250	8430	6920
280	10400	8700

Fa0 : Permissible maximum axial load

Fr : Radial force acting on the shaft

Fr0 : Permissible maximum radial load at the end of the shaft

Fr max : Permissible maximum radial load at the shaft end





Permissible load calculations are based on a bearing life of Lh10 20,000 hours according to ISO 281.

\* For Zone 2/22 radial loads, see page 23.

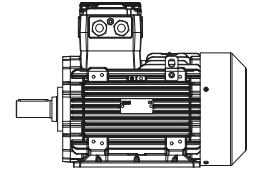
# Zone 1/21 Axial Loads

HORIZONTAL MOUNTING - Permissible Axial Loads  
 Mounting Positions IM: B3, B5, B6, B7, B8, B14, B34, B35

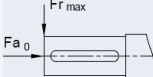

Frame Size	Push			Pull
	Fr = 0	Fr = Fr <sub>0</sub>	Fr = Fr <sub>max</sub>	Fr = 0
				
<b>2 Poles 3000 rpm</b>	<b>Fa<sub>0</sub> [N]</b>	<b>Fa<sub>0</sub> [N]</b>	<b>Fa<sub>0</sub> [N]</b>	<b>Fa<sub>0</sub> [N]</b>
100	480	480	480	850
112	480	480	480	850
132	465	465	465	1300
160	2300	950	950	1750
180	2750	1200	1200	2000
200	3200	1350	1350	2900
225	3600	1380	1380	3300
250	4430	1650	1650	3950
280	5000	2900	2300	3280
<b>4 Poles 1500 rpm</b>	<b>Fa<sub>0</sub> [N]</b>	<b>Fa<sub>0</sub> [N]</b>	<b>Fa<sub>0</sub> [N]</b>	<b>Fa<sub>0</sub> [N]</b>
100	480	480	480	1250
112	480	480	480	1250
132	465	465	465	1810
160	3000	1200	1200	2410
180	3650	1510	1510	2800
200	4300	1600	1600	4000
225	4910	1760	1760	4600
250	6000	2160	2160	5300
280	7200	3400	3000	5400
<b>6 Poles 1000 rpm</b>	<b>Fa<sub>0</sub> [N]</b>	<b>Fa<sub>0</sub> [N]</b>	<b>Fa<sub>0</sub> [N]</b>	<b>Fa<sub>0</sub> [N]</b>
100	480	480	480	1500
112	480	480	480	1500
132	465	465	465	2210
160	3550	1340	1340	2910
180	4250	1750	1750	3400
200	5150	1950	1950	4800
225	5750	2100	2100	5170
250	6950	2570	2570	6400
280	8700	2570	2700	6700

Fa<sub>0</sub> : Permissible maximum axial load

Fr : Radial force acting on the shaft

Fr<sub>0</sub> : Permissible maximum radial load at the end of the shaft

Fr<sub>max</sub> : Permissible maximum radial load at the shaft end



Permissible load calculations are based on a bearing life of L<sub>h10</sub> 20,000 hours according to ISO 281.

\* For Zone 2/22 axial loads, see page 24.

## Zone 1/21 Axial Loads

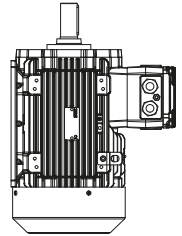
VERTICAL MOUNTING - Shaft Up - Permissible Axial Loads  
Mounting Positions IM: V3, V6, V19, V35, V37

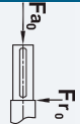
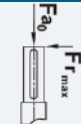

Frame Size	Push			Pull
	Fr = 0	Fr = Fr <sub>0</sub>	Fr = Fr <sub>max</sub>	Fr = 0
				
<b>2 Poles 3000 rpm</b>	<b>Fa<sub>0</sub> [N]</b>	<b>Fa<sub>0</sub> [N]</b>	<b>Fa<sub>0</sub> [N]</b>	<b>Fa<sub>0</sub> [N]</b>
100	415	415	415	920
112	400	400	400	950
132	290	290	290	1500
160	2150	800	800	2100
180	2500	950	950	2450
200	2850	850	850	3700
225	3140	800	800	4200
250	3650	980	980	5100
280	4100	1850	1500	4700
<b>4 Poles 1500 rpm</b>	<b>Fa<sub>0</sub> [N]</b>	<b>Fa<sub>0</sub> [N]</b>	<b>Fa<sub>0</sub> [N]</b>	<b>Fa<sub>0</sub> [N]</b>
100	390	390	390	1350
112	370	370	370	1350
132	250	250	250	2100
160	2710	900	900	2890
180	3150	1100	1100	3500
200	3800	1100	1100	4800
225	4100	1010	1010	5700
250	4910	1200	1200	7000
280	5500	1550	1550	8000
<b>6 Poles 1000 rpm</b>	<b>Fa<sub>0</sub> [N]</b>	<b>Fa<sub>0</sub> [N]</b>	<b>Fa<sub>0</sub> [N]</b>	<b>Fa<sub>0</sub> [N]</b>
100	390	390	390	1640
112	370	370	370	1670
132	250	250	250	2500
160	3230	1100	1100	3360
180	3850	1350	1300	4000
200	4600	1350	1350	5700
225	4950	1400	1400	6600
250	6000	1540	1540	8000
280	7100	2150	2200	9000

Fa<sub>0</sub> : Permissible maximum axial load

Fr : Radial force acting on the shaft

Fr<sub>0</sub> : Permissible maximum radial load at the end of the shaft

Fr<sub>max</sub> : Permissible maximum radial load at the shaft end



Permissible load calculations are based on a bearing life of L<sub>h10</sub> 20,000 hours according to ISO 281.

\* For Zone 2/22 radial loads, see page 25.

## Zone 1/21 Axial Loads

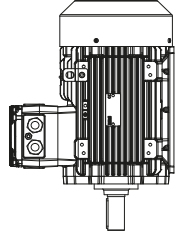
VERTICAL MOUNTING - Shaft Down - Permissible Axial Loads  
Mounting Positions IM: V1, V5, V15, V17, V18

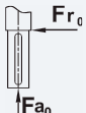
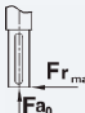

Frame Size	Push			Pull
	Fr = 0	Fr = Fr <sub>0</sub>	Fr = Fr <sub>max</sub>	Fr = 0
				
<b>2 Poles 3000 rpm</b>	<b>Fa<sub>0</sub> [N]</b>	<b>Fa<sub>0</sub> [N]</b>	<b>Fa<sub>0</sub> [N]</b>	<b>Fa<sub>0</sub> [N]</b>
100	550	550	550	800
112	560	550	560	780
132	640	640	640	1200
160	2600	1350	1350	1570
180	3250	1700	1700	1700
200	4000	1980	2000	2500
225	4630	2300	2300	2600
250	5530	2710	2710	3200
280	6500	3500	3800	2400
<b>4 Poles 1500 rpm</b>	<b>Fa<sub>0</sub> [N]</b>	<b>Fa<sub>0</sub> [N]</b>	<b>Fa<sub>0</sub> [N]</b>	<b>Fa<sub>0</sub> [N]</b>
100	575	575	575	1150
112	595	595	595	1150
132	670	670	670	1700
160	3430	1600	1600	2180
180	4300	2150	2150	2400
200	5300	2550	2550	3400
225	6150	3000	3000	3700
250	7540	3800	3800	4450
280	9800	5800	6300	3700
<b>6 Poles 1000 rpm</b>	<b>Fa<sub>0</sub> [N]</b>	<b>Fa<sub>0</sub> [N]</b>	<b>Fa<sub>0</sub> [N]</b>	<b>Fa<sub>0</sub> [N]</b>
100	575	575	575	1440
112	595	595	595	1420
132	670	670	670	2050
160	3940	1810	1810	2670
180	4800	2300	2300	3000
200	6000	2750	2750	4200
225	7000	3300	3300	4500
250	8500	3950	3950	5500
280	10900	6100	6100	5200

Fa<sub>0</sub> : Permissible maximum axial load

Fr : Radial force acting on the shaft

Fr<sub>0</sub> : Permissible maximum radial load at the end of the shaft

Fr<sub>max</sub> : Permissible maximum radial load at the shaft end

Permissible load calculations are based on a bearing life of Lh10 20,000 hours according to ISO 281.

\* For Zone 2/22 radial loads, see page 26.

# Product Type Codes of Exproof Motors

**4**    **ZL**    **160**    **M**    **4**    **E**    **PD**    **BA**    **162**

4	----->	<p>Motor Efficiency Classes:                  2: IE2                  3: IE3                  4: IE4</p>
ZL	----->	<p>Basic Motor Types:                  TG : Cast iron housing ATEX Zone 1-21 motors                  ZL : Aluminum housing ATEX Zone 2-22 motors                  ZG : Cast iron housing ATEX Zone 2-22 motors</p>
160	----->	<p>Frame Size: 63, 71, 80, 90, 100, 112, 132, 160, 180, 200, 225, 250, 280, 315                  Height of the Shaft axis from feet base of motor (mm)</p>
M	----->	<p>Housing Length                  S : Short                  M: Medium                  L : Long</p>
4	----->	<p>Number of Poles                  2 : 2 Poles 3000 rpm                  4 : 4 Poles 1500 rpm                  6 : 6 Poles 1000 rpm</p>
E	----->	<p>Core Length: A, B, C, D, E, F, G</p>
PD	----->	<p>Construction Types / Flange Types                  PD : B3 Foot Mounted                  FA : B5 Flange                  FC : B14 Flange                  FS : Special Flange                  PA : B35                  PC : B34                  PS : Foot mounted with special flange                  Y0..Y9 : With Flange for gearbox connection                  PX : Foot mounted without drive end shield                  XX : Without foot and drive end shield                  Z0-Z9 : Foot mounted Yılmaz type</p>
BA	----->	<p>Electrical Specifications                  AA..ZZ Voltage, Frequency and Electrical features</p> <p>1st digit: Voltage and Frequency                  A : 230/400V 50Hz                  B : 400/690V 50Hz                  C : 240/415V 50Hz                  D : 415/720V 50Hz                  E : 230/400V 60Hz                  F : 400/690V 60Hz                  G : 220V 60Hz                  H : 290/500V 50Hz                  I : 220/380V 60Hz                  J : 380/660V 60Hz</p> <p>2nd digit: Additional Electrical features                  0: Standard motor, basic version                  A: Motors with thermistor                  C: Motors with thermal switch                  K: Motors with thermistor and anti-condensation heater</p>
162	----->	<p>Additional Motor Features                  162 : IP66 (All EX motors have a minimum of IP66 protection.)</p>

**ZONE 2-22  
EX MOTORS**



# Zone 2-22 Ex-Proof Motors Electrical Characteristics

II 3G Ex ec IIC T4 Gc  
II 3D Ex tc IIIC (T120°C ~ T140°C) Dc

400V 50Hz 3000 rpm

Duty Cycle : S1 (Continuous Operation)  
Insulation Class : F (155°C)



Voltage (V)	Type	Rated Values								Starting Values		Break Down Torque	Moment of Inertia	B3 Motor Weight	Sound Pressure Level
		Power	Speed	Current	Torque	Power Factor	Efficiency % $\eta$			Current	Torque				
		kW	rpm	A	Nm	Cos $\phi$	4/4	3/4	1/2	I <sub>A</sub> /I <sub>N</sub>	M <sub>A</sub> /M <sub>N</sub>				
230/400	2ZL063M2A	0,18	2800	0,50	0,61	0,77	67,5	66,0	62,0	4,5	2,9	3,0	0,00012	3,80	51
	2ZL063M2B	0,25	2800	0,67	0,85	0,78	69,0	68,0	63,5	4,5	2,9	3,0	0,00015	4,00	51
	2ZL071M2A	0,37	2790	0,90	1,26	0,80	74,2	74,5	72,5	5,0	2,5	2,8	0,00031	5,70	54
	2ZL071M2B	0,55	2790	1,27	1,88	0,82	75,8	77,0	76,0	5,0	2,8	2,9	0,00037	6,20	54

400V 50Hz 1500 rpm

Duty Cycle : S1 (Continuous Operation)  
Insulation Class : F (155°C)



Voltage (V)	Type	Rated Values								Starting Values		Break Down Torque	Moment of Inertia	B3 Motor Weight	Sound Pressure Level
		Power	Speed	Current	Torque	Power Factor	Efficiency % $\eta$			Current	Torque				
		kW	rpm	A	Nm	Cos $\phi$	4/4	3/4	1/2	I <sub>A</sub> /I <sub>N</sub>	M <sub>A</sub> /M <sub>N</sub>				
230/400	2ZL063M4B	0,12	1400	0,42	0,82	0,70	60,1	60,5	54,5	3,0	2,1	2,3	0,00018	4,00	42
	2ZL063M4C	0,18	1400	0,56	1,23	0,71	64,7	65,8	61,5	3,0	2,1	2,3	0,00022	4,40	42
	2ZL071M4B	0,25	1425	0,71	1,68	0,69	74,0	73,5	70,5	4,4	2,0	3,0	0,00067	6,30	46
	2ZL071M4C	0,37	1425	1,00	2,47	0,70	76,1	75,5	71,5	4,6	2,0	3,0	0,00082	7,00	46
	2ZL080M4B	0,55	1440	1,45	3,65	0,71	77,1	76,7	75,0	5,2	2,0	3,0	0,00175	9,70	50

400V 50Hz 1000 rpm

Duty Cycle : S1 (Continuous Operation)  
Insulation Class : F (155°C)



Voltage (V)	Type	Rated Values								Starting Values		Break Down Torque	Moment of Inertia	B3 Motor Weight	Sound Pressure Level
		Power	Speed	Current	Torque	Power Factor	Efficiency % $\eta$			Current	Torque				
		kW	rpm	A	Nm	Cos $\phi$	4/4	3/4	1/2	I <sub>A</sub> /I <sub>N</sub>	M <sub>A</sub> /M <sub>N</sub>				
230/400	2ZL071M6B	0,18	920	0,60	1,87	0,67	64,5	63,0	57,0	3,2	1,9	2,3	0,00076	6,10	42
	2ZL071M6C	0,25	920	0,78	2,59	0,69	66,5	66,0	61,0	3,3	1,9	2,3	0,00096	6,70	42
	2ZL080M6A	0,37	925	1,08	3,82	0,69	71,4	71,5	70,0	4,0	2,0	2,6	0,00176	9,10	45
	2ZL080M6B	0,55	932	1,50	5,64	0,72	73,5	74,0	71,0	4,2	2,1	2,6	0,00202	9,80	45

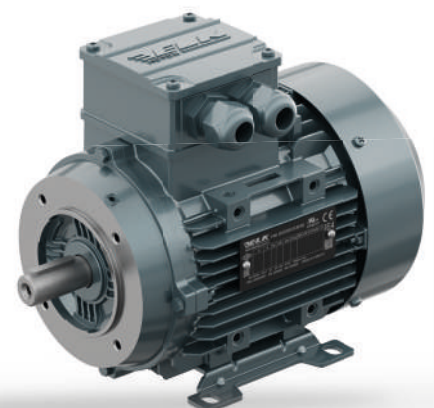

**ZONE 2-22  
EX MOTORS**



**IE3**

**Motors**

# Zone 2-22 Ex-Proof Motors Electrical Characteristics

II 3G Ex ec IIC T4 Gc  
II 3D Ex tc IIIC (T120°C ~ T140°C) Dc

400V 50Hz 3000 rpm

Duty Cycle : S1 (Continuous Operation)  
Insulation Class : F (155°C)



Voltage (V)	Type	Rated Values							Starting Values		Break Down Torque	Moment of Inertia	B3 Motor Weight	Sound Pressure Level	
		Power	Speed	Current	Torque	Power Factor	Efficiency % $\eta$			Current					Torque
		kW	rpm	A	Nm	Cos $\phi$	4/4	3/4	1/2	I <sub>A</sub> /I <sub>N</sub>					M <sub>A</sub> /M <sub>N</sub>
230/400	3ZL063M2A	0,18	2805	0,48	0,61	0,77	70,0	68,5	62,8	4,5	3,0	3,1	0,00012	4,00	51
	3ZL063M2B	0,25	2805	0,65	0,85	0,79	71,0	69,7	64,2	4,6	3,0	3,1	0,00015	4,20	51
	3ZL071M2B	0,37	2830	0,84	1,25	0,82	76,6	77,0	75,0	6,0	2,8	3,0	0,00037	6,30	53
	3ZL071M2C	0,55	2830	1,19	1,86	0,84	79,4	80,2	78,8	6,1	2,9	3,3	0,00046	7,00	53
	3ZL080M2B	0,75	2880	1,59	2,49	0,84	80,7	82,0	81,5	6,7	3,0	3,6	0,00103	9,60	54
	3ZL080M2C	1,10	2880	2,26	3,64	0,85	82,7	83,0	82,4	6,8	3,1	3,8	0,00124	10,9	54
	3ZL090S2B	1,50	2900	2,97	4,94	0,86	84,8	85,4	84,2	7,6	3,1	3,9	0,00178	15,2	59
	3ZL090L2C	2,20	2900	4,25	7,24	0,87	85,9	86,8	86,1	7,2	3,0	3,8	0,00221	17,5	59
	3ZL100L2C	3,00	2910	5,58	9,85	0,89	87,1	87,6	86,9	7,9	3,0	4,1	0,00450	23,8	62
400/690	3ZL112M2C	4,00	2915	7,28	13,1	0,90	88,1	88,8	88,2	7,5	2,6	3,9	0,00618	29,4	65
	3ZL132S2B	5,50	2945	9,90	17,8	0,90	89,2	89,0	88,6	8,9	2,9	3,9	0,01732	45,7	67
	3ZL132S2C	7,50	2945	13,2	24,3	0,91	90,1	90,5	89,7	8,4	2,6	4,0	0,02104	52,0	67
	3ZL160M2B	11,0	2950	19,7	35,6	0,88	91,2	91,0	90,5	8,5	2,6	3,9	0,03318	79,7	69
	3ZL160M2C	15,0	2950	26,5	48,6	0,89	91,9	92,1	91,6	8,9	3,1	4,2	0,03913	87,8	69
	3ZL160L2D	18,5	2945	31,7	60,0	0,91	92,4	92,7	92,3	8,9	3,1	4,2	0,04409	95,2	69
	3ZL180M2B	22,0	2957	38,1	71,1	0,90	92,7	92,9	92,0	8,6	3,1	3,9	0,06299	131	70
	3ZL200L2B	30,0	2965	52,0	96,6	0,89	93,6	93,8	93,6	8,6	3,2	3,5	0,16168	181	72
	3ZL200L2C	37,0	2965	63,3	119	0,90	93,7	94,1	93,8	8,6	3,2	3,4	0,17458	191	72
	3ZL225M2C	45,0	2970	76,8	145	0,90	94,0	94,4	94,2	8,6	3,3	3,1	0,25353	335	74
	3ZG250M2C	55,0	2970	93,3	177	0,90	94,4	94,8	94,5	8,6	3,3	3,4	0,38000	425	75

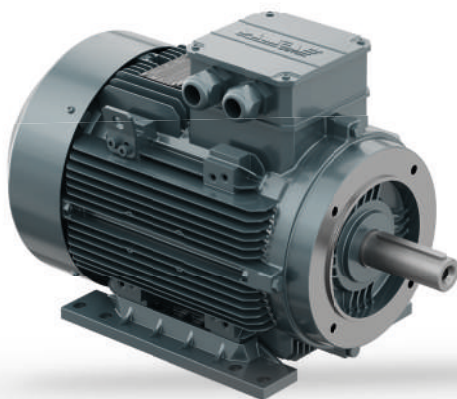

# Zone 2-22 Ex-Proof Motors Electrical Characteristics

II 3G Ex ec IIC T4 Gc  
II 3D Ex tc IIIC (T120°C ~ T140°C) Dc

400V 50Hz 1500 rpm

Duty Cycle : S1 (Continuous Operation)  
Insulation Class : F (155°C)



Voltage (V)	Type	Rated Values							Starting Values		Break Down Torque	Moment of Inertia	B3 Motor Weight	Sound Pressure Level	
		Power	Speed	Current	Torque	Power Factor	Efficiency % $\eta$			Current					Torque
		kW	rpm	A	Nm	Cos $\phi$	4/4	3/4	1/2	I <sub>A</sub> /I <sub>N</sub>					M <sub>A</sub> /M <sub>N</sub>
230/400	3ZL063M4B	0,12	1405	0,37	0,82	0,70	66,0	64,9	58,2	3,7	2,3	2,7	0,00018	4,10	42
	3ZL063M4C	0,18	1405	0,52	1,22	0,71	69,9	68,8	63,6	3,8	2,3	2,8	0,00022	4,50	42
	3ZL071M4C	0,25	1435	0,67	1,66	0,71	76,0	75,4	71,5	5,4	2,1	2,8	0,00082	7,10	45
	3ZL071M4D	0,37	1435	0,97	2,46	0,70	78,5	78,2	75,0	5,5	2,2	2,9	0,00093	7,80	45
	3ZL080M4C	0,55	1450	1,34	3,62	0,73	80,8	80,4	77,0	5,9	2,1	3,0	0,00200	10,5	50
	3ZL080M4D	0,75	1450	1,77	4,94	0,74	82,5	82,3	80,0	6,2	2,5	3,1	0,00227	11,6	50
	3ZL090S4C	1,10	1450	2,51	7,25	0,75	84,5	84,3	82,0	7,0	2,6	3,4	0,00355	16,3	51
	3ZL090L4D	1,50	1445	3,30	9,91	0,77	85,3	85,2	83,0	7,2	2,8	3,4	0,00411	18,0	51
	3ZL100L4C	2,20	1450	4,65	14,5	0,79	86,7	87,2	86,0	7,2	2,8	3,6	0,00775	24,4	53
	3ZL100L4D	3,00	1450	6,26	19,8	0,79	87,7	88,0	87,0	7,2	2,8	3,6	0,00888	27,0	53
400/690	3ZL112M4D	4,00	1460	8,05	26,2	0,81	88,6	88,4	87,5	7,4	2,8	3,8	0,01437	32,6	58
	3ZL132S4C	5,50	1465	10,9	36,0	0,81	89,6	90,2	90,0	7,0	3,0	3,3	0,03059	53,4	61
	3ZL132M4D	7,50	1465	14,8	48,9	0,81	90,4	91,0	90,5	7,8	3,2	3,4	0,03418	56,6	61
	3ZL160M4C	11,0	1465	21,0	71,7	0,83	91,5	92,1	91,7	7,6	2,8	3,3	0,07011	89,2	63
	3ZL160L4E	15,0	1465	28,7	97,8	0,82	92,1	92,4	91,9	7,8	2,8	3,5	0,08579	97,5	63
	3ZL180M4C	18,5	1475	35,0	120	0,82	92,6	93,2	92,9	7,7	3,0	3,3	0,12901	128	64
	3ZL180L4D	22,0	1470	41,4	143	0,82	93,0	93,7	93,7	8,0	3,0	3,4	0,14667	141	64
	3ZL200L4D	30,0	1475	54,5	194	0,85	93,6	94,1	94,0	8,0	3,0	3,4	0,28413	193	65
	3ZL225S4C	37,0	1478	65,7	239	0,87	93,9	94,5	94,5	8,3	3,2	3,3	0,38229	320	66
	3ZG225M4D	45,0	1477	80,0	291	0,86	94,2	94,7	94,7	8,6	3,3	3,2	0,44100	350	67
3ZG250M4D	55,0	1482	95,3	354	0,88	94,6	95,1	95,2	8,7	3,3	3,2	0,73000	460	68	



# Zone 2-22 Ex-Proof Motors Electrical Characteristics

II 3G Ex ec IIC T4 Gc  
II 3D Ex tc IIIC (T120°C ~ T140°C) Dc

400V 50Hz 1000 rpm

Duty Cycle : S1 (Continuous Operation)  
Insulation Class : F (155°C)



Voltage (V)	Type	Rated Values								Starting Values		Break Down Torque	Moment of Inertia	B3 Motor Weight	Sound Pressure Level
		Power	Speed	Current	Torque	Power Factor	Efficiency % $\eta$			Current	Torque				
		kW	rpm	A	Nm	Cos $\phi$	4/4	3/4	1/2	I <sub>A</sub> /I <sub>N</sub>	M <sub>A</sub> /M <sub>N</sub>				
230/400	3ZL071M6C	0,18	930	0,55	1,85	0,69	68,0	67,4	62,6	3,6	2,0	2,4	0,00096	6,80	41
	3ZL071M6D	0,25	930	0,77	2,57	0,67	70,0	69,7	66,0	3,6	2,2	2,5	0,00116	7,50	41
	3ZL080M6B	0,37	930	1,03	3,80	0,70	74,0	73,8	70,0	4,4	2,1	2,6	0,00202	9,90	43
	3ZL080M6C	0,55	935	1,47	5,62	0,70	77,2	77,3	74,4	4,3	2,2	2,7	0,00228	11,0	43
	3ZL090S6B	0,75	945	1,96	7,58	0,70	78,9	79,2	77,6	4,7	2,2	2,7	0,00354	16,0	46
	3ZL090L6C	1,10	940	2,75	11,2	0,71	81,0	80,8	79,4	5,0	2,2	2,7	0,00428	16,8	46
	3ZL100L6B	1,50	955	3,50	15,0	0,75	82,5	82,7	81,4	5,3	2,1	2,8	0,00821	22,5	50
3ZL112M6B	2,20	960	4,95	21,9	0,76	84,3	84,5	83,5	5,5	2,2	3,0	0,01319	29,6	56	
400/690	3ZL132S6B	3,00	970	6,55	29,4	0,77	85,6	85,5	84,5	6,2	2,1	3,0	0,03051	46,7	58
	3ZL132M6C	4,00	970	8,52	39,4	0,78	86,8	87,0	85,5	6,2	2,2	2,9	0,03493	50,9	58
	3ZL132M6D	5,50	965	11,6	54,4	0,78	88,0	88,9	88,5	6,2	2,2	2,8	0,03934	57,3	58
	3ZL160M6D	7,50	972	15,6	73,7	0,78	89,1	89,4	88,4	6,3	2,6	3,0	0,07870	96,0	61
	3ZL160L6E	11,0	972	23,1	108	0,76	90,3	90,9	90,5	6,6	2,9	3,1	0,08580	104	62
	3ZL180L6E	15,0	975	30,8	147	0,77	91,2	91,6	91,0	6,7	2,9	3,1	0,15264	141	63
	3ZL200L6C	18,5	977	36,4	181	0,80	91,7	91,8	91,8	6,1	2,6	2,6	0,36100	164	64
	3ZL200L6D	22,0	978	42,5	215	0,81	92,2	92,9	93,0	6,2	2,6	2,6	0,39355	180	64
	3ZL225S6C	30,0	985	57,6	291	0,81	92,9	92,9	92,6	6,6	2,9	2,7	0,60000	340	65
	3ZG250M6C	37,0	988	68,8	358	0,83	93,4	93,6	93,5	7,3	2,9	2,8	0,82000	435	65
	3ZG280S6B	45,0	989	83,5	435	0,83	93,7	93,9	93,2	6,8	2,9	2,8	1,45000	590	65
	3ZG280M6C	55,0	989	102	531	0,83	94,1	94,4	93,5	6,9	2,9	2,8	1,65000	620	65



**ZONE 2-22  
EX MOTORS**



**IE4**

**Motors**

# Zone 2-22 Ex-Proof Motors Electrical Characteristics

II 3G Ex ec IIC T4 Gc  
II 3D Ex tc IIIC (T120°C ~ T140°C) Dc

400V 50Hz 3000 rpm

Duty Cycle : S1 (Continuous Operation)  
Insulation Class : F (155°C)



Voltage (V)	Type	Rated Values								Starting Values		Break Down Torque	Moment of Inertia	B3 Motor Weight	Sound Pressure Level
		Power	Speed	Current	Torque	Power Factor	Efficiency % $\eta$			Current	Torque				
		kW	rpm	A	Nm	Cos $\phi$	4/4	3/4	1/2	I <sub>A</sub> /I <sub>N</sub>	M <sub>A</sub> /M <sub>N</sub>				
230/400	4ZL071M2B	0,37	2825	0,83	1,25	0,82	78,1	78,3	76,5	5,7	2,8	3,2	0,00037	6,50	58
	4ZL071M2C	0,55	2825	1,17	1,86	0,83	81,5	81,9	79,5	6,2	2,9	3,5	0,00046	7,50	58
	4ZL080M2C	0,75	2875	1,56	2,49	0,83	83,5	84,0	81,0	6,8	2,9	3,5	0,00124	11,0	59
	4ZL080M2D	1,10	2880	2,19	3,65	0,85	85,2	85,5	84,9	7,5	2,9	3,7	0,00135	12,0	59
	4ZL090S2C	1,50	2900	2,95	4,94	0,85	86,5	86,9	85,7	7,8	2,9	3,7	0,00221	17,2	64
	4ZL090L2D	2,20	2900	4,20	7,24	0,86	88,0	88,5	87,6	8,2	3,0	3,8	0,00234	20,0	64
	4ZL100L2D	3,00	2910	5,50	9,85	0,88	89,1	89,5	88,5	8,5	3,0	4,0	0,00503	25,9	67
400/690	4ZL112M2D	4,00	2940	7,30	13,0	0,88	90,0	90,3	89,7	8,7	3,0	4,2	0,00734	32,2	70
	4ZL132S2C	5,50	2945	9,60	17,8	0,91	90,9	90,9	90,0	8,9	3,2	4,2	0,02104	52,5	72
	4ZL132S2D	7,50	2945	13,0	24,5	0,91	91,7	92,2	91,8	8,5	3,2	4,2	0,02290	55,6	72
	4ZL160M2C	11,0	2950	18,9	35,6	0,91	92,6	92,7	91,2	8,5	3,3	4,3	0,03913	89,0	74
	4ZL160M2D	15,0	2950	25,6	48,6	0,91	93,3	93,6	92,8	8,5	3,3	4,3	0,04409	96,8	74
	4ZL160L2E	18,5	2955	31,4	59,8	0,91	93,7	93,8	92,9	8,7	3,2	4,3	0,05000	114	74
	4ZL180M2C	22,0	2960	37,2	71,1	0,91	94,0	94,4	93,5	8,9	3,0	4,0	0,07000	158	74
	4ZL200L2C	30,0	2970	51,0	96,5	0,90	94,5	94,7	94,0	8,3	3,2	3,7	0,17500	215	74
	4ZL200L2D	37,0	2970	63,3	120	0,89	94,8	95,0	94,2	8,3	3,2	4,0	0,20000	235	74
	4ZL225M2D	45,0	2975	76,0	145	0,90	95,0	95,2	94,9	9,0	3,4	4,2	0,29000	355	74
	4ZG250M2D	55,0	2975	92,6	177	0,90	95,3	95,5	94,9	8,2	3,4	3,7	0,52000	445	74
	4ZG280S2C	75,0	2982	126	240	0,90	95,6	95,6	95,2	7,7	2,7	3,2	0,98000	620	76
	4ZG280M2D	90,0	2985	151	288	0,90	95,8	95,9	95,0	7,7	2,8	3,5	1,10000	640	77
	4ZG315S2C	110	2985	184	352	0,90	96,0	96,0	95,7	7,8	3,1	4,0	1,60000	1110	77
	4ZG315M2D	132	2986	220	422	0,90	96,2	96,3	96,0	8,0	3,1	4,0	2,00000	1070	77
	4ZG315L2E	160	2986	267	512	0,90	96,3	96,5	96,0	8,0	3,2	4,0	2,20000	1230	78
	4ZG315L2F	200	2987	332	639	0,90	96,5	96,7	96,3	8,1	3,2	4,0	2,70000	1340	78



# Zone 2-22 Ex-Proof Motors Electrical Characteristics

II 3G Ex ec IIC T4 Gc  
II 3D Ex tc IIIC (T120°C ~ T140°C) Dc

400V 50Hz 1500 rpm

Duty Cycle : S1 (Continuous Operation)  
Insulation Class : F (155°C)



Voltage (V)	Type	Rated Values								Starting Values		Break Down Torque	Moment of Inertia	B3 Motor Weight	Sound Pressure Level
		Power	Speed	Current	Torque	Power Factor	Efficiency % $\eta$			Current	Torque				
		kW	rpm	A	Nm	Cos $\phi$	4/4	3/4	1/2	I <sub>A</sub> /I <sub>N</sub>	M <sub>A</sub> /M <sub>N</sub>				
400/690	4ZL132S4D	5,50	1470	11,1	35,7	0,78	91,9	91,8	90,6	7,7	3,8	3,7	0,03418	56,7	61
	4ZL132M4F*	7,50	1470	14,6	48,7	0,80	92,6	92,7	91,5	7,7	3,8	4,0	0,04316	72,8	62
	4ZL160M4E	11,0	1470	21,0	71,5	0,81	93,3	93,5	93,3	7,7	3,0	3,6	0,08600	100	64
	4ZL160L4F*	15,0	1475	29,5	97,5	0,79	93,9	94,1	93,4	8,0	3,7	3,9	0,12000	112	64
	4ZL180M4D	18,5	1475	34,6	120	0,82	94,2	94,4	94,0	8,0	3,1	3,5	0,14700	142	64
	4ZL180L4E	22,0	1475	41,0	142	0,82	94,5	94,7	94,2	8,2	3,2	3,8	0,17000	168	64
	4ZL200L4E	30,0	1480	53,0	194	0,86	94,9	95,3	95,2	8,3	3,3	3,8	0,35000	235	64
	4ZL225S4D	37,0	1480	65,0	239	0,86	95,2	95,7	95,0	8,1	3,3	3,3	0,44100	350	70
	4ZL225M4E	45,0	1480	79,2	290	0,86	95,4	95,6	95,6	8,2	3,5	3,3	0,52000	370	70
	4ZG250M4E	55,0	1485	94,3	354	0,88	95,7	96,0	96,0	8,5	3,3	3,4	1,05000	490	70
	4ZG280S4D	75,0	1487	127	482	0,89	96,0	96,3	96,2	8,7	3,0	3,2	1,50000	670	70
	4ZG280M4E	90,0	1488	152	578	0,89	96,1	96,3	96,3	8,9	3,1	3,2	1,95000	720	71
	4ZG315S4D	110	1491	187	705	0,88	96,3	96,5	96,0	8,9	2,8	3,3	2,80000	1200	73
	4ZG315M4E	132	1492	225	845	0,88	96,4	96,7	96,2	8,9	2,9	3,3	3,30000	1270	73
	4ZG315L4F	160	1492	272	1024	0,88	96,6	96,9	96,5	8,9	3,1	3,4	4,40000	1370	76
	4ZG315L4G	200	1492	339	1280	0,88	96,7	97,0	96,6	8,8	3,3	3,5	5,20000	1520	76

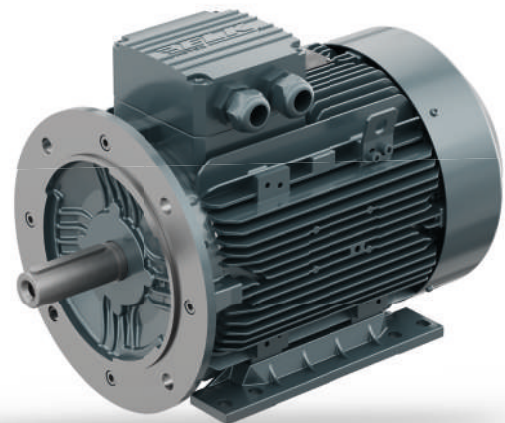

Motors marked with \* do not have a symmetrical housing structure.

# Zone 2-22 Ex-Proof Motors Electrical Characteristics

II 3G Ex ec IIC T4 Gc  
II 3D Ex tc IIIC (T120°C ~ T140°C) Dc

400V 50Hz 1000 rpm

Duty Cycle : S1 (Continuous Operation)  
Insulation Class : F (155°C)



Voltage (V)	Type	Rated Values								Starting Values		Break Down Torque	Moment of Inertia	B3 Motor Weight	Sound Pressure Level
		Power	Speed	Current	Torque	Power Factor	Efficiency % $\eta$			Current	Torque				
		kW	rpm	A	Nm	Cos $\phi$	4/4	3/4	1/2	I <sub>A</sub> /I <sub>N</sub>	$\lambda$ /M <sub>N</sub>				
400/690	4ZG315S6C	75,0	994	133	721	0,85	95,4	95,5	95,2	8,80	2,80	3,50	3,50000	1215	67
	4ZG315M6D	90,0	994	160	865	0,85	95,6	95,7	95,8	8,80	2,80	3,70	3,80000	1250	67
	4ZG315L6E	110	995	195	1056	0,85	95,8	96,1	95,7	8,60	2,80	3,70	4,50000	1280	68
	4ZG315L6F	132	995	231	1267	0,86	96,0	96,2	95,8	8,50	2,80	3,70	5,20000	1350	68
	4ZG315L6G	160	995	280	1536	0,86	96,2	96,4	96,3	7,70	2,90	3,80	5,55000	1446	70



**ZONE 1-21  
EX MOTORS**



**IE3**

**Motors**

# Zone 1-21 Ex-Proof Motors Electrical Characteristics

II 2G Ex db IIC T4 Gb  
II 2D Ex tb IIIC T120°C Db

400V 50Hz 3000 rpm

Duty Cycle : S1 (Continuous Operation)  
Insulation Class : F (155°C)



Voltage (V)	Type	Rated Values								Starting Values		Break Down Torque	Moment of Inertia	B3 Motor Weight	Sound Pressure Level
		Power	Speed	Current	Torque	Power Factor	Efficiency % $\eta$			Current	Torque				
		kW	rpm	A	Nm	Cos $\phi$	4/4	3/4	1/2	I <sub>A</sub> /I <sub>N</sub>	M <sub>A</sub> /M <sub>N</sub>				
230/400	3TG100L2C	3,00	2910	5,58	9,85	0,89	87,1	87,6	86,9	7,9	3,0	4,1	0,00450	50,2	62
	3TG112M2C	4,00	2915	7,28	13,1	0,90	88,1	88,8	88,2	7,5	2,6	3,9	0,00618	59,0	65
400/690	3TG132S2B	5,50	2945	9,90	17,8	0,90	89,2	89,0	88,6	8,9	2,9	3,9	0,01732	83,0	67
	3TG132S2C	7,50	2945	13,2	24,3	0,91	90,1	90,5	89,7	8,4	2,6	4,0	0,02104	89,3	67
	3TG160M2B	11,0	2950	19,7	35,6	0,88	91,2	91,0	90,5	8,5	2,6	3,9	0,03318	157	69
	3TG160M2C	15,0	2950	26,5	48,6	0,89	91,9	92,1	91,6	8,9	3,1	4,2	0,03913	165	69
	3TG160L2D	18,5	2945	31,7	60,0	0,91	92,4	92,7	92,3	8,9	3,1	4,2	0,04409	172	69
	3TG180M2B	22,0	2957	38,1	71,1	0,90	92,7	92,9	92,0	8,6	3,1	3,9	0,06299	211	70
	3TG200L2B	30,0	2965	52,0	96,6	0,89	93,6	93,8	93,6	8,6	3,2	3,5	0,16168	290	72
	3TG200L2D	37,0	2970	64,0	119	0,89	93,7	93,9	93,3	8,9	3,4	3,5	0,20000	310	72
	3TG225M2C	45,0	2970	76,8	145	0,90	94,0	94,4	94,2	8,6	3,3	3,1	0,25353	407	74
	3TG250M2C	55,0	2970	93,3	177	0,90	94,4	94,8	94,5	8,6	3,3	3,4	0,38000	491	75

400V 50Hz 1500 rpm

Duty Cycle : S1 (Continuous Operation)  
Insulation Class : F (155°C)



Voltage (V)	Type	Rated Values								Starting Values		Break Down Torque	Moment of Inertia	B3 Motor Weight	Sound Pressure Level
		Power	Speed	Current	Torque	Power Factor	Efficiency % $\eta$			Current	Torque				
		kW	rpm	A	Nm	Cos $\phi$	4/4	3/4	1/2	I <sub>A</sub> /I <sub>N</sub>	M <sub>A</sub> /M <sub>N</sub>				
230/400	3TG100L4C	2,20	1450	4,65	14,5	0,79	86,7	87,2	86,0	7,2	2,8	3,6	0,00775	50,8	53
	3TG100L4D	3,00	1450	6,26	19,8	0,79	87,7	88,0	87,0	7,2	2,8	3,6	0,00888	53,4	53
400/690	3TG112M4D	4,00	1460	8,05	26,2	0,81	88,6	88,4	87,5	7,4	2,8	3,8	0,01437	62,2	58
	3TG132S4C	5,50	1465	10,9	36,0	0,81	89,6	90,2	90,0	7,0	3,0	3,3	0,03059	90,7	61
	3TG132M4D	7,50	1465	14,8	48,9	0,81	90,4	91,0	90,5	7,8	3,2	3,4	0,03418	93,9	61
	3TG160M4C	11,0	1465	21,0	71,7	0,83	91,5	92,1	91,7	7,6	2,8	3,3	0,07011	166	63
	3TG160L4E	15,0	1465	28,7	97,8	0,82	92,1	92,4	91,9	7,8	2,8	3,5	0,08579	174	63
	3TG180M4C	18,5	1475	35,0	120	0,82	92,6	93,2	92,9	7,7	3,0	3,3	0,12901	208	64
	3TG180L4D	22,0	1470	41,4	143	0,82	93,0	93,7	93,7	8,0	3,0	3,4	0,14667	221	64
	3TG200L4D	30,0	1475	54,5	194	0,85	93,6	94,1	94,0	8,0	3,0	3,4	0,28413	302	65
	3TG225S4C	37,0	1478	65,7	239	0,87	93,9	94,5	94,5	8,3	3,2	3,3	0,38229	392	66
	3TG225M4D	45,0	1477	80,0	291	0,86	94,2	94,7	94,7	8,6	3,3	3,2	0,44100	422	67
	3TG250M4D	55,0	1482	95,3	354	0,88	94,6	95,1	95,2	8,7	3,3	3,2	0,73000	526	68

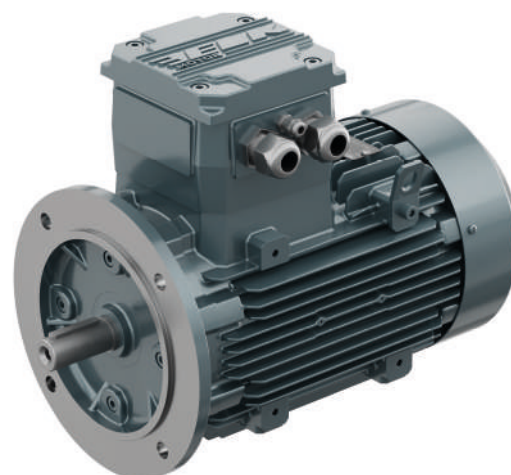

# Zone 1-21 Ex-Proof Motors Electrical Characteristics

II 2G Ex db IIC T4 Gb  
II 2D Ex tb IIIC T120°C Db

400V 50Hz 1000 rpm

Duty Cycle : S1 (Continuous Operation)  
Insulation Class : F (155°C)



Voltage (V)	Type	Rated Values								Starting Values		Break Down Torque	Moment of Inertia	B3 Motor Weight	Sound Pressure Level
		Power	Speed	Current	Torque	Power Factor	Efficiency % $\eta$			Current	Torque				
		kW	rpm	A	Nm	Cos $\phi$	4/4	3/4	1/2	I <sub>A</sub> /I <sub>N</sub>	M <sub>A</sub> /M <sub>N</sub>				
230/400	3TG100L6B	1,50	955	3,50	15,0	0,75	82,5	82,7	81,4	5,3	2,1	2,8	0,00821	51,9	50
	3TG112M6B	2,20	960	4,95	21,9	0,76	84,3	84,5	83,5	5,5	2,2	3,0	0,01319	59,2	56
400/690	3TG132S6B	3,00	970	6,55	29,4	0,77	85,6	85,5	84,5	6,2	2,1	3,0	0,03051	84,0	58
	3TG132M6C	4,00	970	8,52	39,4	0,78	86,8	87,0	85,5	6,2	2,2	2,9	0,03493	88,2	58
	3TG132M6D	5,50	965	11,6	54,4	0,78	88,0	88,9	88,5	6,2	2,2	2,8	0,03934	94,6	58
	3TG160M6D	7,50	972	15,6	73,7	0,78	89,1	89,4	88,4	6,3	2,6	3,0	0,07870	173	61
	3TG160L6E	11,0	972	23,1	108	0,76	90,3	90,9	90,5	6,6	2,9	3,1	0,08580	181	62
	3TG180L6E	15,0	975	30,8	147	0,77	91,2	91,6	91,0	6,7	2,9	3,1	0,15264	221	63
	3TG200L6C	18,5	977	36,4	181	0,80	91,7	91,8	91,8	6,1	2,6	2,6	0,36100	273	64
	3TG200L6D	22,0	978	42,5	215	0,81	92,2	92,9	93,0	6,2	2,6	2,6	0,39355	289	64
	3TG225S6C	30,0	985	57,6	291	0,81	92,9	92,9	92,6	6,6	2,9	2,7	0,60000	412	65
	3TG250M6C	37,0	988	68,8	358	0,83	93,4	93,6	93,5	7,3	2,9	2,8	0,82000	501	65
	3TG280S6B	45,0	989	83,5	435	0,83	93,7	93,9	93,2	6,8	2,9	2,8	1,45000	715	65
	3TG280M6C	55,0	989	102	531	0,83	94,1	94,4	93,5	6,9	2,9	2,8	1,65000	745	65

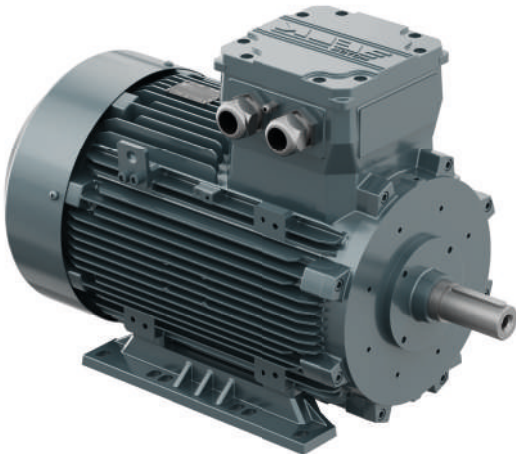

**ZONE 1-21  
EX MOTORS**



**IE4**

**Motors**

# Zone 1-21 Ex-Proof Motors Electrical Characteristics

II 2G Ex db IIC T4 Gb  
II 2D Ex tb IIIC T120°C Db



400V 50Hz 3000 rpm

Duty Cycle : S1 (Continuous Operation)  
Insulation Class : F (155°C)

Voltage (V)	Type	Rated Values							Starting Values		Break Down Torque	Moment of Inertia	B3 Motor Weight	Sound Pressure Level	
		Power	Speed	Current	Torque	Power Factor	Efficiency % $\eta$			Current					Torque
		kW	rpm	A	Nm	Cos $\phi$	4/4	3/4	1/2	I <sub>A</sub> /I <sub>N</sub>					M <sub>A</sub> /M <sub>N</sub>
230/400	4TG100L2D	3,00	2910	5,50	9,85	0,88	89,1	89,5	88,5	8,5	3,0	4,0	0,00503	52,3	67
	4TG112M2D	4,00	2940	7,30	13,0	0,88	90,0	90,3	89,7	8,7	3,0	4,2	0,00734	65,2	70
400/690	4TG132S2C	5,50	2945	9,60	17,8	0,91	90,9	90,9	90,0	8,9	3,2	4,2	0,02104	89,8	72
	4TG132S2D	7,50	2945	13,0	24,5	0,91	91,7	92,2	91,8	8,5	3,2	4,2	0,02290	92,9	72
	4TG160M2C	11,0	2950	18,9	35,6	0,91	92,6	92,7	91,2	8,5	3,3	4,3	0,03913	166	74
	4TG160M2D	15,0	2950	25,6	48,6	0,91	93,3	93,6	92,8	8,5	3,3	4,3	0,04409	174	74
	4TG160L2E	18,5	2955	31,4	59,8	0,91	93,7	93,8	92,9	8,7	3,2	4,3	0,05000	191	74
	4TG180M2C	22,0	2960	37,2	71,1	0,91	94,0	94,4	93,5	8,9	3,0	4,0	0,07000	238	74
	4TG200L2C	30,0	2970	51,0	96,5	0,90	94,5	94,7	94,0	8,9	3,4	3,5	0,20000	344	74
	4TG200L2E	37,0	2970	63,3	120	0,89	94,8	95,0	94,2	9,0	3,8	3,9	0,21250	354	74
	4TG225M2D	45,0	2975	76,0	145	0,90	95,0	95,2	94,9	9,0	3,4	4,2	0,29000	427	74
	4TG250M2D	55,0	2975	92,6	177	0,90	95,3	95,5	94,9	8,2	3,4	3,7	0,52000	511	74
	4TG280S2C	75,0	2982	126	240	0,90	95,6	95,6	95,2	7,7	2,7	3,2	0,98000	738	76
	4TG280M2D	90,0	2985	151	288	0,90	95,8	95,9	95,0	7,7	2,8	3,5	1,10000	758	77



400V 50Hz 1500 rpm

Duty Cycle : S1 (Continuous Operation)  
Insulation Class : F (155°C)

Voltage (V)	Type	Rated Values							Starting Values		Break Down Torque	Moment of Inertia	B3 Motor Weight	Sound Pressure Level	
		Power	Speed	Current	Torque	Power Factor	Efficiency % $\eta$			Current					Torque
		kW	rpm	A	Nm	Cos $\phi$	4/4	3/4	1/2	I <sub>A</sub> /I <sub>N</sub>					M <sub>A</sub> /M <sub>N</sub>
400/690	4TG132S4D	5,50	1470	11,1	35,7	0,78	91,9	91,8	90,6	7,7	3,8	3,7	0,03418	94,0	61
	4TG160M4E	11,0	1470	21,0	71,5	0,81	93,3	93,5	93,3	7,7	3,0	3,6	0,08600	176	64
	4TG160L4F	15,0	1475	29,5	97,5	0,79	93,9	94,1	93,4	8,0	3,7	3,9	0,12000	189	64
	4TG180M4D	18,5	1475	34,6	120	0,82	94,2	94,4	94,0	8,0	3,1	3,5	0,14700	222	64
	4TG180L4E	22,0	1475	41,0	142	0,82	94,5	94,7	94,2	8,2	3,2	3,8	0,17000	248	64
	4TG200L4E	30,0	1480	53,0	194	0,86	94,9	95,3	95,2	8,3	3,3	3,8	0,35000	344	64
	4TG225S4D	37,0	1480	65,0	239	0,86	95,2	95,7	95,0	8,1	3,3	3,3	0,44100	422	70
	4TG225M4E	45,0	1480	79,2	290	0,86	95,4	95,6	95,6	8,2	3,5	3,3	0,52000	442	70
	4TG250M4E	55,0	1485	94,3	354	0,88	95,7	96,0	96,0	8,5	3,3	3,4	1,05000	556	70
	4TG280S4D	75,0	1487	127	482	0,89	96,0	96,3	96,2	8,7	3,0	3,2	1,50000	795	70
	4TG280M4E	90,0	1488	152	578	0,89	96,1	96,3	96,3	8,9	3,1	3,2	1,95000	845	71

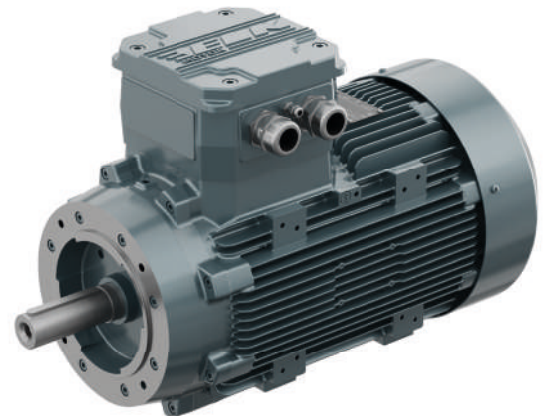

**EX MOTORS**



**Dimensions**

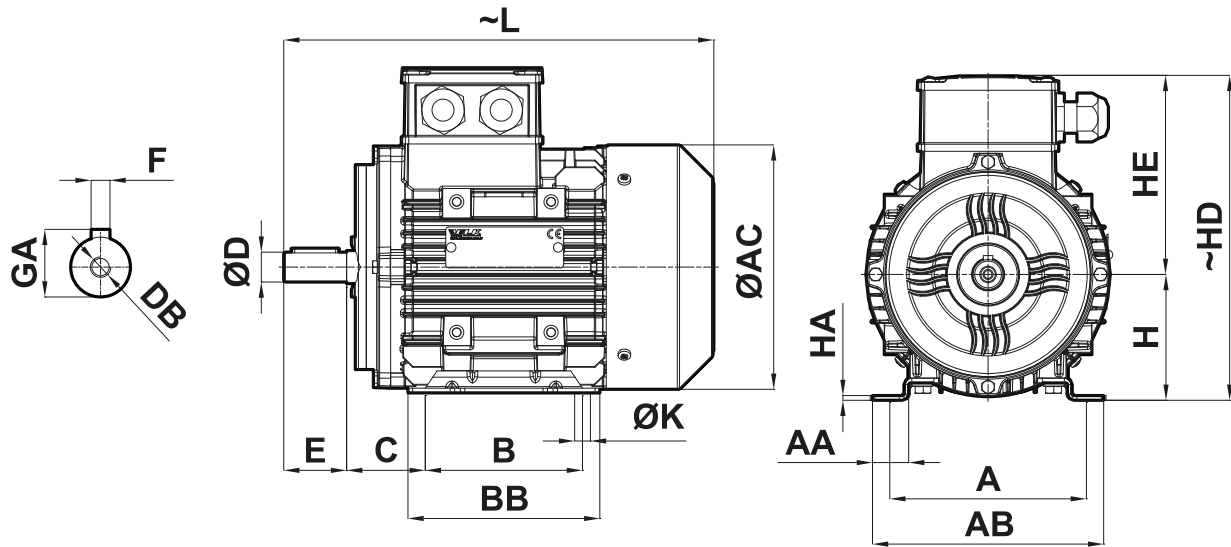

Frame Size	Efficiency Class	No. of Poles	D <sup>[1]</sup>	E	L	AC	H <sup>[2]</sup>	HE	HD	F	GA	DB	C	ØK	B	BB	HA	AA	A	AB
063M	IE2/IE3	2-4-6-8	11	23	213	119	63	101	164	4	12,5	M4	40	7	80	104	3	18	100	115
071M	IE2/IE3/IE4	2-4-6-8	14	30	242	137	71	118	189	5	16	M5	45	7	90	110	3	19	112	128
080M	IE2/IE3/IE4	2-4-6-8	19	40	274	155	80	127	207	6	21,5	M6	50	10	100	122	3	25	125	148
090S	IE3/IE4	2-4-6-8	24	50	325	176	90	136	226	8	27	M8	56	10	100	151	4	27	140	167
090L	IE3/IE4	2-4-6-8	24	50	325	176	90	136	226	8	27	M8	56	10	125	151	4	27	140	167
100L	IE3/IE4	2-4-6-8	28	60	369	193	100	149	249	8	31	M10	63	12	140	170	4	31	160	191
112M	IE3/IE4	2-4-6-8	28	60	392	215	112	161	273	8	31	M10	70	12	140	177	4	36	190	217
112M <sup>[3]</sup>	IE4	4	28	60	430	215	112	161	273	8	31	M10	70	12	140	177	4	36	190	217
132S	IE3/IE4	2-4-6-8	38	80	495	257	132	182	314	10	41	M12	89	12	140	212	5	34	216	246
132M	IE3/IE4	2-4-6-8	38	80	495	257	132	182	314	10	41	M12	89	12	178	212	5	34	216	246
132M <sup>[4]</sup>	IE4	4	38	80	543	257	132	182	314	10	41	M12	89	12	178	212	5	34	216	246
160M	IE3/IE4	2-4-6-8	42	110	605	316	160	226	386	12	45	M16	108	14,5	210	328	15	65	254	293
160L	IE3/IE4	2-4-6-8	42	110	605	316	160	226	386	12	45	M16	108	14,5	254	328	15	65	254	293
160L <sup>[5]</sup>	IE4	4	42	110	657	316	160	226	386	12	45	M16	108	14,5	254	328	15	65	254	293
180M	IE3/IE4	2-4-6-8	48	110	696	348	180	242	422	14	51,5	M16	121	14,5	241	319	15	63	279	316
180L	IE3/IE4	2-4-6-8	48	110	696	348	180	242	422	14	51,5	M16	121	14,5	279	319	15	63	279	316
200M	IE3/IE4	2-4-6-8	55	110	737	396	200	294	494	16	59	M20	133	18,5	267	350	20	76	318	372
200L	IE3/IE4	2-4-6-8	55	110	737	396	200	294	494	16	59	M20	133	18,5	305	350	20	76	318	372
225S	IE3/IE4	2	55	110	800	438	225	311,5	536,5	16	59	M20	149	18,5	286	360	20	90	356	417
		4-6-8	60	140	830					18	64									
225M	IE3/IE4	2	55	110	800	438	225	311,5	536,5	16	59	M20	149	18,5	311	360	20	90	356	417
		4-6-8	60	140	830					18	64									
250S	IE3/IE4	2	60	140	896	481	250	337	587	18	64	M20	168	24	311	433	32	105	406	475
		4-6-8	65							69										
250M	IE3/IE4	2	60	140	896	481	250	337	587	18	64	M20	168	24	349	433	32	105	406	475
		4-6-8	65							69										
280S	IE3/IE4	2	65	140	1012	547	280	402	682	18	69	M20	190	24	368	500	35	105	457	531
		4-6-8	75							79,5										
280M	IE3/IE4	2	65	140	1012	547	280	402	682	18	69	M20	190	24	419	500	35	105	457	531
		4-6-8	75							79,5										
315S	IE3/IE4	2	65	140	1242	622	315	499	814	18	69	M20	216	28	406	636	33	157	508	626
		4-6-8	80	170	1272					22	85									
315M	IE3/IE4	2	65	140	1242	622	315	499	814	18	69	M20	216	28	457	636	33	157	508	626
		4-6-8	80	170	1272					22	85									
315L	IE3/IE4	2	65	140	1389	622	315	499	814	18	69	M20	216	28	508	800	35	145	508	623
		4-6-8	90	170	1419					25	95									

[1] Tolerance "j6" up to 28mm, "k6" from 28mm to 48mm, "m6" over 48mm TS EN 50347

[2] Tolerance 063-250 "-0.5mm" / 280-315 "-1mm" TS EN 50347

[3] 4kW IE4 Motors

[4] 7.5kW IE4 Motors

[5] 15kW IE4 Motors

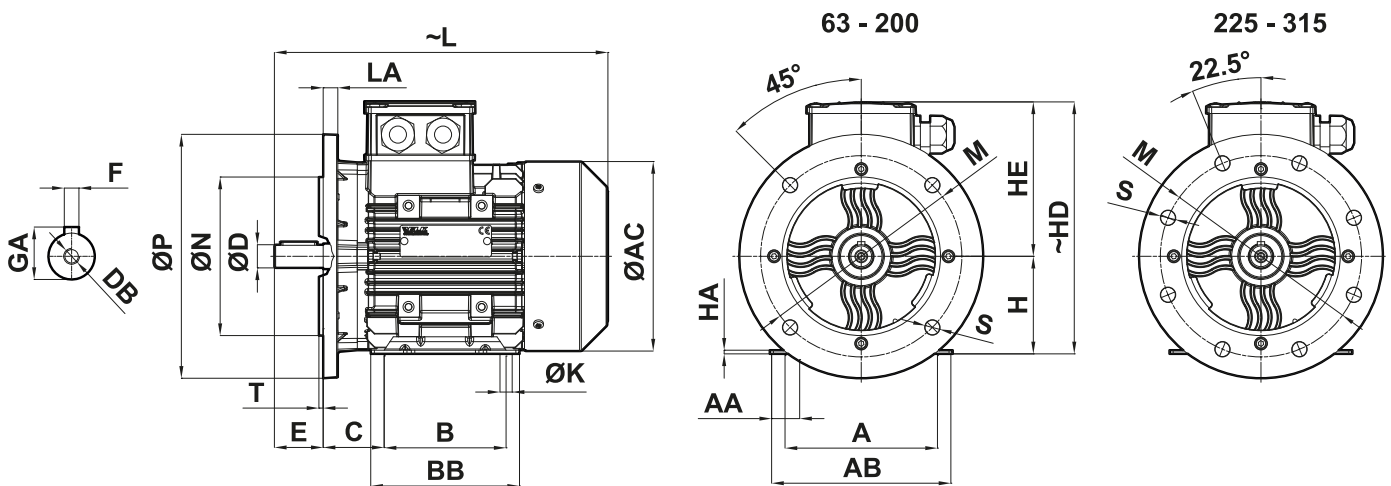

Frame Size	Efficiency Class	No. of Poles	D <sup>[1]</sup>	E	N <sup>[2]</sup>	P	T	LA	L	AC	S	M	H <sup>[3]</sup>	HE	HD	F	GA	DB	C	ØK	B	BB	HA	AA	A	AB
063M	IE2/IE3	2-4-6-8	11	23	95	140	3	8	213	119	10	115	63	101	160	4	12,5	M4	40	7	80	104	3	18	100	115
071M	IE2/IE3/IE4	2-4-6-8	14	30	110	160	3,5	8	242	137	10	130	71	118	183	5	16	M5	45	7	90	110	3	19	112	128
080M	IE2/IE3/IE4	2-4-6-8	19	40	130	200	3,5	12	274	155	12	165	80	127	207	6	21,5	M6	50	10	100	122	3	25	125	148
090S	IE3/IE4	2-4-6-8	24	50	130	200	3,5	12	325	176	12	165	90	136	226	8	27	M8	56	10	100	151	4	27	140	167
090L	IE3/IE4	2-4-6-8	24	50	130	200	3,5	12	325	176	12	165	90	136	226	8	27	M8	56	10	125	151	4	27	140	167
100L	IE3/IE4	2-4-6-8	28	60	180	250	4	15	369	193	14,5	215	100	149	248	8	31	M10	63	12	140	170	4	31	160	191
112M	IE3/IE4	2-4-6-8	28	60	180	250	4	15	392	215	14,5	215	112	161	273	8	31	M10	70	12	140	177	4	36	190	217
112M <sup>[4]</sup>	IE4	4	28	60	180	250	4	15	430	215	14,5	215	112	161	273	8	31	M10	70	12	140	177	4	36	190	217
132S	IE3/IE4	2-4-6-8	38	80	230	300	4	20	495	257	14,5	265	132	182	312	10	41	M12	89	12	140	212	5	34	216	246
132M	IE3/IE4	2-4-6-8	38	80	230	300	4	20	495	257	14,5	265	132	182	312	10	41	M12	89	12	178	212	5	34	216	246
132M <sup>[5]</sup>	IE4	4	38	80	230	300	4	20	543	257	14,5	265	132	182	312	10	41	M12	89	12	178	212	5	34	216	246
160M	IE3/IE4	2-4-6-8	42	110	250	350	5	20	605	316	18,5	300	160	226	380	12	45	M16	108	14,5	210	328	15	65	254	293
160L	IE3/IE4	2-4-6-8	42	110	250	350	5	20	605	316	18,5	300	160	226	380	12	45	M16	108	14,5	254	328	15	65	254	293
160L <sup>[6]</sup>	IE4	4	42	110	250	350	5	20	657	316	18,5	300	160	226	380	12	45	M16	108	14,5	254	328	15	65	254	293
180M	IE3/IE4	2-4-6-8	48	110	250	350	5	14	696	348	18,5	300	180	242	419	14	51,5	M16	121	14,5	241	319	15	63	279	316
180L	IE3/IE4	2-4-6-8	48	110	250	350	5	14	696	348	18,5	300	180	242	419	14	51,5	M16	121	14,5	279	319	15	63	279	316
200M	IE3/IE4	2-4-6-8	55	110	300	400	5	14	737	396	18,5	350	200	294	494	16	59	M20	133	18,5	267	350	20	76	318	372
200L	IE3/IE4	2-4-6-8	55	110	300	400	5	14	737	396	18,5	350	200	294	494	16	59	M20	133	18,5	305	350	20	76	318	372
225S	IE3/IE4	2	55	110	350	450	5	20	800	438	18,5	400	225	312	537	16	59	M20	149	18,5	286	360	20	90	356	417
		830	18	64																						
225M	IE3/IE4	2	55	110	350	450	5	20	800	438	18,5	400	225	312	537	16	59	M20	149	18,5	311	360	20	90	356	417
		830	18	64																						
250S	IE3/IE4	2	60	140	450	550	5	20	896	481	18,5	500	250	337	587	18	64	M20	168	24	311	433	32	105	406	475
		69																								
250M	IE3/IE4	2	60	140	450	550	5	20	896	481	18,5	500	250	337	587	18	64	M20	168	24	349	433	32	105	406	475
		69																								
280S	IE3/IE4	2	65	140	450	550	5	20	1012	547	18,5	500	280	402	682	18	69	M20	190	24	368	500	35	105	457	531
		79,5																								
280M	IE3/IE4	2	65	140	450	550	5	20	1012	547	18,5	500	280	402	682	18	69	M20	190	24	419	500	35	105	457	531
		79,5																								
315S	IE3/IE4	2	65	140	550	660	6	25	1242	622	24	600	315	499	814	18	69	M20	216	28	406	636	33	157	508	626
		1272	22	85																						
315M	IE3/IE4	2	65	140	550	660	6	22	1242	622	24	600	315	499	814	18	69	M20	216	28	457	636	33	157	508	626
		1272	22	85																						
315L	IE3/IE4	2	60	140	550	660	6	22	1389	622	24	600	315	499	814	18	69	M20	216	28	508	800	35	145	508	623
		1419	25	95																						

[1] Tolerance "j6" up to 28mm, "k6" from 28mm to 48mm, "m6" over 48mm TS EN 50347

[2] Tolerance "j6" up to 250mm, "h6" over 250mm TS EN 50347

[3] Tolerance 063-250 "-0.5mm" / 280-315 "-1mm" TS EN 50347

[4] 4kW IE4 Motors

[5] 7.5kW IE4 Motors

[6] 15kW IE4 Motors

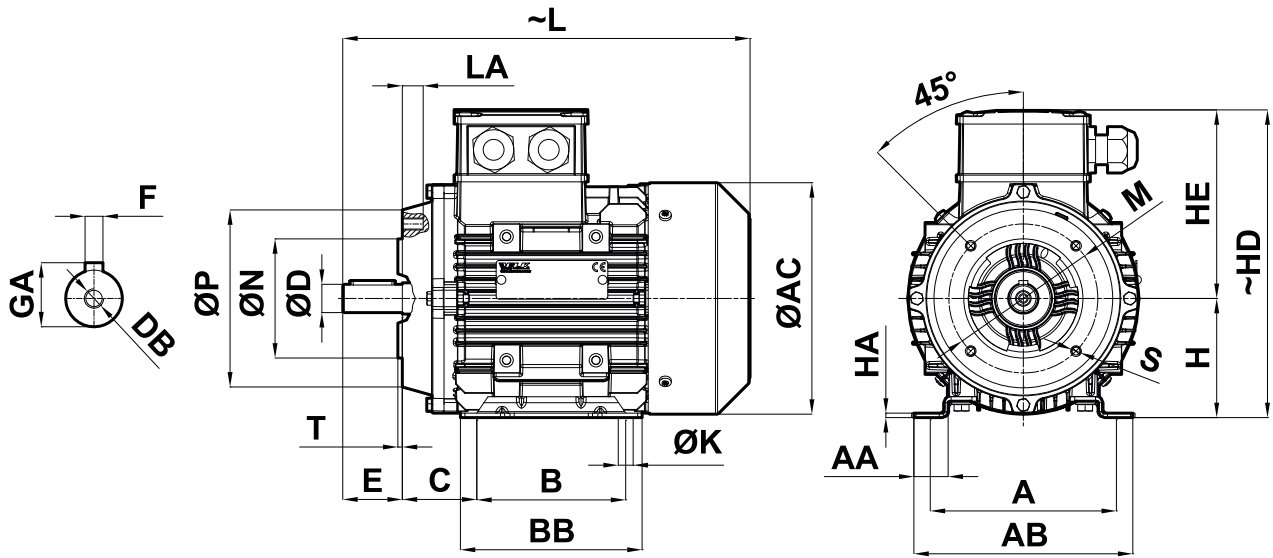

Frame Size	Efficiency Class	No. of Poles	D <sup>[1]</sup>	N <sup>[2]</sup>	P	E	T	LA	L	AC	S	M	H <sup>[3]</sup>	HE	HD	F	GA	DB	C	ØK	B	BB	HA	AA	A	AB
063M	IE2/IE3	2-4-6-8	11	60	90	23	2,5	10	213	119	M5	75	63	101	164	4	12,5	M4	40	7	80	104	3	18	100	115
071M	IE2/IE3/IE4	2-4-6-8	14	70	105	30	2,5	12	242	137	M6	85	71	118	189	5	16	M5	45	7	90	110	3	19	112	128
080M	IE2/IE3/IE4	2-4-6-8	19	80	119	40	3	12	274	155	M6	100	80	127	207	6	21,5	M6	50	10	100	122	3	25	125	148
090S	IE3/IE4	2-4-6-8	24	95	137	50	3	15	325	176	M8	115	90	136	226	8	27	M8	56	10	100	151	4	27	140	167
090L	IE3/IE4	2-4-6-8	24	95	137	50	3	15	325	176	M8	115	90	136	226	8	27	M8	56	10	125	151	4	27	140	167
100L	IE3/IE4	2-4-6-8	28	110	160	60	3,5	17	369	193	M8	130	100	149	249	8	31	M10	63	12	140	170	4	31	160	191
112M	IE3/IE4	2-4-6-8	28	110	160	60	3,5	17	392	215	M8	130	112	161	273	8	31	M10	70	12	140	177	4	36	190	217
112M <sup>[4]</sup>	IE4	4	28	110	160	60	3,5	17	430	215	M8	130	112	161	273	8	31	M10	70	12	140	177	4	36	190	217
132S	IE3/IE4	2-4-6-8	38	130	200	80	3,5	20	495	257	M10	165	132	182	314	10	41	M12	89	12	140	212	5	34	216	246
132M	IE3/IE4	2-4-6-8	38	130	200	80	3,5	20	495	257	M10	165	132	182	314	10	41	M12	89	12	178	212	5	34	216	246
132M <sup>[5]</sup>	IE4	4	38	130	200	80	3,5	20	543	257	M10	165	132	182	314	10	41	M12	89	12	178	212	5	34	216	246
160M	IE3/IE4	2-4-6-8	42	180	250	110	4	23	605	316	M12	215	160	226	386	12	45	M16	108	14,5	210	323	15	65	254	295
160L	IE3/IE4	2-4-6-8	42	180	250	110	4	23	605	316	M12	215	160	226	386	12	45	M16	108	14,5	254	323	15	65	254	295
160L <sup>[6]</sup>	IE4	4	42	180	250	110	4	23	657	316	M12	215	160	226	386	12	45	M16	108	14,5	254	323	15	65	254	295

[1] Tolerance "j6" up to 28mm, "k6" over 28mm TS EN 50347

[2] Tolerance "j6" TS EN 50347

[3] Tolerance "-0.5mm" TS EN 50347

[4] 4kW IE4 Motors

[5] 7.5kW IE4 Motors

[6] 15kW IE4 Motors

# Zone 1-21 Ex-Proof Motors

## B3 Construction Type

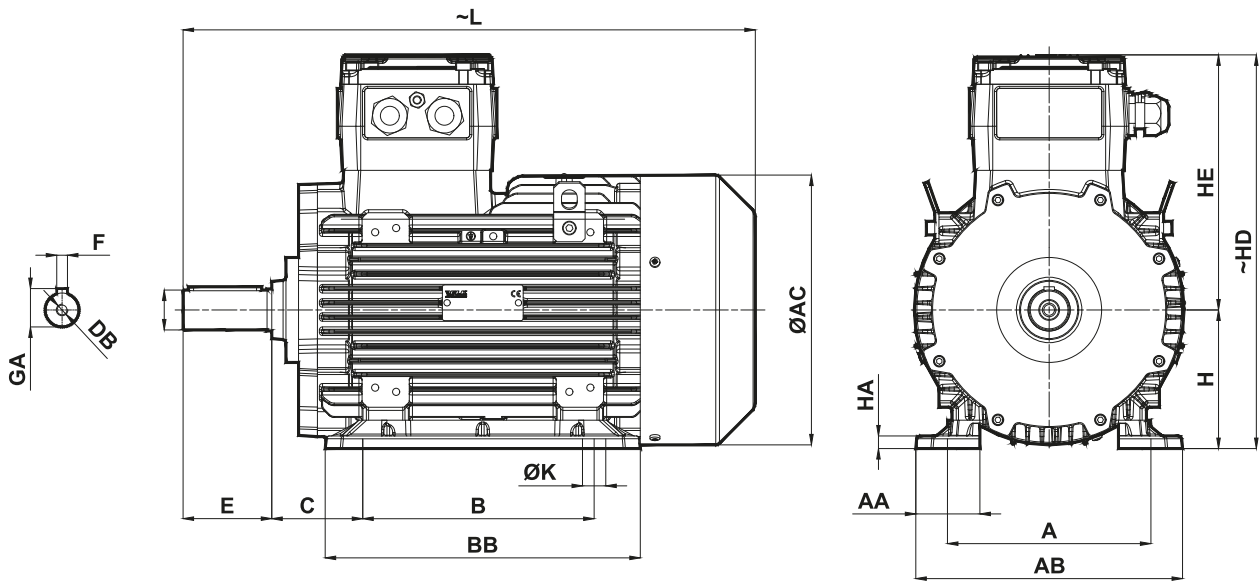

Frame Size	Efficiency Class	No. of Poles	D <sup>[1]</sup>	E	L	AC	H <sup>[2]</sup>	HE	HD	F	GA	DB	C	ØK	B	BB	HA	AA	A	AB
100L	IE3/IE4	2-4-6	28	60	446	193	100	211	311	8	31	M10	63	12	140	262	10	51	160	204
112M	IE3/IE4	2-4-6	28	60	459	215	112	223	335	8	31	M10	70	12	140	262	10	51	190	225
132S	IE3/IE4	2-4-6	38	80	545	257	132	243	375	10	41	M12	89	12	140	300	12	61	216	254
132M	IE3/IE4	2-4-6	38	80	545	257	132	243	375	10	41	M12	89	12	140	300	12	61	216	254
160M	IE3/IE4	2-4-6	42	110	709	316	160	281	441	12	45	M16	108	14,5	210	366	15	75	254	293
160L	IE3/IE4	2-4-6	42	110	709	316	160	281	441	12	45	M16	108	14,5	210	366	15	75	254	293
180M	IE3/IE4	2-4-6	48	110	767	348	180	299	478	14	51,5	M16	121	14,5	241	395	17	76	279	315
180L	IE3/IE4	2-4-6	48	110	767	348	180	299	478	14	51,5	M16	121	14,5	241	395	17	76	279	315
200M	IE3/IE4	2-4-6	55	110	808	396	200	333	553	16	59	M20	133	18,5	267	444	18	88	318	365
200L	IE3/IE4	2-4-6	55	110	808	396	200	333	553	16	59	M20	133	18,5	267	444	18	88	318	365
225S	IE3/IE4	2	55	110	911,5	438	225	373	598	16	59	M20	149	18,5	286	473	18	94	356	407
		4-6	60	140	941,5					18	64									
225M	IE3/IE4	2	55	110	911,5	438	225	373	598	16	59	M20	149	18,5	286	473	18	94	356	407
		4-6	60	140	941,5					18	64									
250S	IE3/IE4	2	60	140	971	481	250	395	645	18	64	M20	168	24	311	488	18	112	406	465
		4-6	65								69									
250M	IE3/IE4	2	60	140	971	481	250	395	645	18	64	M20	168	24	311	488	18	112	406	465
		4-6	65								69									
280S	IE3/IE4	2	65	140	1103	547	280	431	711	18	69	M20	190	24	368	564	25	118	457	516
		4-6	75								79,5									
280M	IE3/IE4	2	65	140	1103	547	280	431	711	18	69	M20	190	24	368	564	25	118	457	516
		4-6	75								79,5									

[1] Tolerance "j6" up to 28mm, "k6" from 28mm to 48mm, "m6" over 48mm TS EN 50347

[2] Tolerance 063-250 "-0.5mm" / 280-315 "-1mm" TS EN 50347

# Zone 1-21 Ex-Proof Motors

## B5-B35 Construction Type

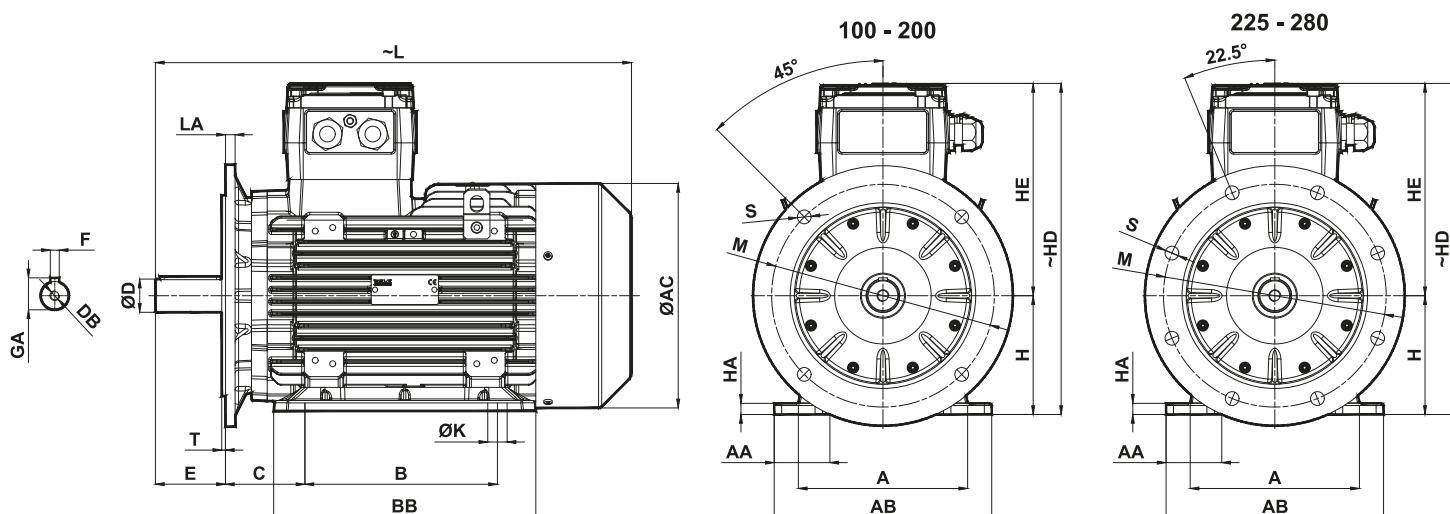

Frame Size	Efficiency Class	No. of Poles	D <sup>[1]</sup>	E	N <sup>[2]</sup>	P	T	LA	L	AC	S	M	H <sup>[3]</sup>	HE	HD	F	GA	DB	C	ØK	B	BB	HA	AA	A	AB
100L	IE3/IE4	2-4-6	28	60	180	250	4	12	446	193	14,5	215	100	211	311	8	31	M10	63	12	140	262	10	51	160	204
112M	IE3/IE4	2-4-6	28	60	180	250	4	12	459	215	14,5	215	112	223	335	8	31	M10	70	12	140	262	10	51	190	225
132S	IE3/IE4	2-4-6	38	80	230	300	4	12	545	257	14,5	265	132	243	375	10	41	M12	89	12	140	300	12	61	216	254
132M	IE3/IE4	2-4-6	38	80	230	300	4	12	545	257	14,5	265	132	243	375	10	41	M12	89	12	140	300	12	61	216	254
160M	IE3/IE4	2-4-6	42	110	250	350	5	13	709	316	18,5	300	160	281	441	12	45	M16	108	14,5	210	366	15	75	254	293
160L	IE3/IE4	2-4-6	42	110	250	350	5	13	709	316	18,5	300	160	281	441	12	45	M16	108	14,5	210	366	15	75	254	293
180M	IE3/IE4	2-4-6	48	110	250	350	5	13	767	348	18,5	300	180	299	478	14	51,5	M16	121	14,5	241	395	17	76	279	315
180L	IE3/IE4	2-4-6	48	110	250	350	5	13	767	348	18,5	300	180	299	478	14	51,5	M16	121	14,5	241	395	17	76	279	315
200M	IE3/IE4	2-4-6	55	110	300	400	5	15	808	396	18,5	350	200	333	553	16	59	M20	133	18,5	267	444	18	88	318	365
200L	IE3/IE4	2-4-6	55	110	300	400	5	15	808	396	18,5	350	200	333	553	16	59	M20	133	18,5	267	444	18	88	318	365
225S	IE3/IE4	2	55	110	350	450	5	20	911,5	438	18,5	400	225	373	598	18	59	M20	149	18,5	286	473	18	94	356	407
		4-6	60	140					941,5								64									
225M	IE3/IE4	2	55	110	350	450	5	20	911,5	438	18,5	400	225	373	598	18	59	M20	149	18,5	286	473	18	94	356	407
		4-6	60	140					941,5								64									
250S	IE3/IE4	2	60	140	450	550	5	20	971	481	18,5	500	250	395	645	18	64	M20	168	24	311	488	18	112	406	465
		4-6	65						69																	
250M	IE3/IE4	2	60	140	450	550	5	20	971	481	18,5	500	250	395	645	18	64	M20	168	24	311	488	18	112	406	465
		4-6	65						69																	
280S	IE3/IE4	2	65	140	450	550	5	20	1103	547	18,5	500	280	431	711	18	69	M20	190	24	419	564	25	118	457	516
		4-6	75						79,5																	
280M	IE3/IE4	2	65	140	450	550	5	20	1103	547	18,5	500	280	431	711	18	69	M20	190	24	419	564	25	118	457	516
		4-6	75						79,5																	

[1] Tolerance "j6" up to 28mm, "k6" from 28mm to 48mm, "m6" over 48mm TS EN 50347

[2] Tolerance "j6" up to 250mm, "h6" over 250mm TS EN 50347

[3] Tolerance 063-250 "-0.5mm" / 280-315 "-1mm" TS EN 50347

# Zone 1-21 Ex-Proof Motors

# B14-B34 Construction Type

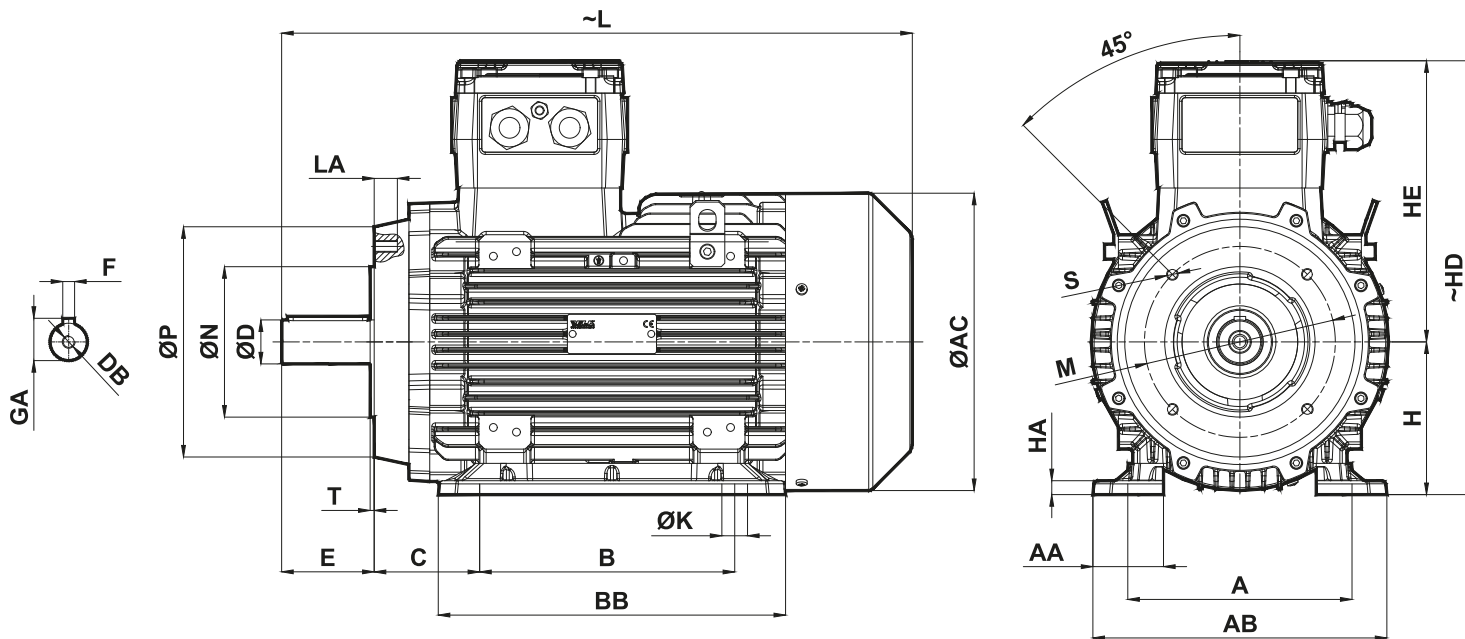

Frame Size	Efficiency Class	No. of Poles	D <sup>[1]</sup>	N <sup>[2]</sup>	P	E	T	LA	L	AC	S	M	H <sup>[3]</sup>	HE	HD	F	GA	DB	C	ØK	B	BB	HA	AA	A	AB
100L	IE3/IE4	2-4-6	28	110	160	60	3,5	17	446	193	M8	130	100	211	311	8	31	M10	63	12	140	262	10	51	160	204
112M	IE3/IE4	2-4-6	28	110	160	60	3,5	17	459	215	M8	130	112	223	335	8	31	M10	70	12	140	262	10	51	190	225
132S	IE3/IE4	2-4-6	38	130	200	80	3,5	20	545	257	M10	165	132	243	375	10	41	M12	89	12	140	300	12	61	216	254
132M	IE3/IE4	2-4-6	38	130	200	80	3,5	20	545	257	M10	165	132	243	375	10	41	M12	89	12	140	300	12	61	216	254
160M	IE3/IE4	2-4-6	42	180	250	110	4	23	709	316	M12	215	160	281	441	12	45	M16	108	14,5	210	366	15	75	254	293
160L	IE3/IE4	2-4-6	42	180	250	110	4	23	709	316	M12	215	160	281	441	12	45	M16	108	14,5	210	366	15	75	254	293

[1] Tolerance "j6" up to 28mm, "k6" over 28mm TS EN 50347

[2] Tolerance "j6" TS EN 50347

[3] Tolerance "-0.5mm" TS EN 50347

## Zone 2-22 Ex-Proof Motor Nameplate Example

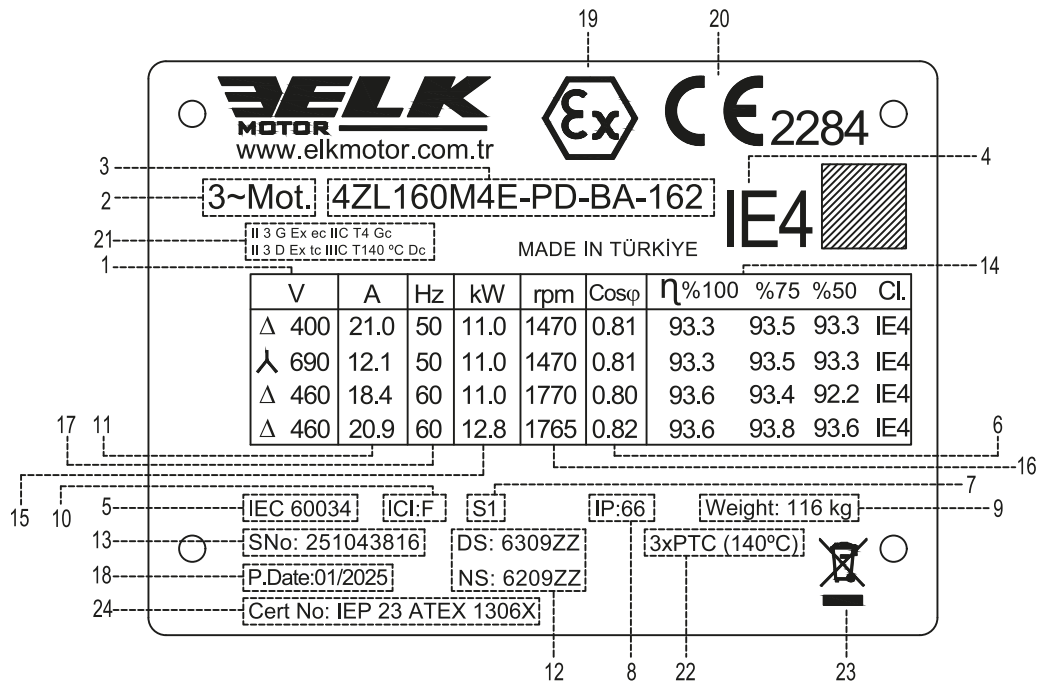

- |                                     |                               |
|-------------------------------------|-------------------------------|
| 1. Rated Voltage                    | 13. Serial Number             |
| 2. Motor Type: 3 Phase Asynchronous | 14. Efficiency                |
| 3. Motor Code                       | 15. Output Power              |
| 4. Efficiency Class                 | 16. Speed                     |
| 5. Manufacture Standard             | 17. Frequency                 |
| 6. Power Factor                     | 18. Production Date           |
| 7. Duty Cycle                       | 19. Ex-Proof Logo             |
| 8. Protection Class                 | 20. CE Mark                   |
| 9. Motor Weight                     | 21. ATEX Classification Codes |
| 10. Insulation Class                | 22. 3xPTC Thermistor          |
| 11. Rated Current                   | 23. WEEE Symbol               |
| 12. Bearing Type                    | 24. Certificate Number        |



The nameplate shows the identification, and the most important technical data. The nameplate also defines the limits of proper usage, and manufacturing year of the motors. The first two digits in the serial number, shows the manufacturing year. For example, 25XXXXXXX shows that the product is manufactured in 2025.

## Zone 1-21 Ex-Proof Motor Nameplate Example

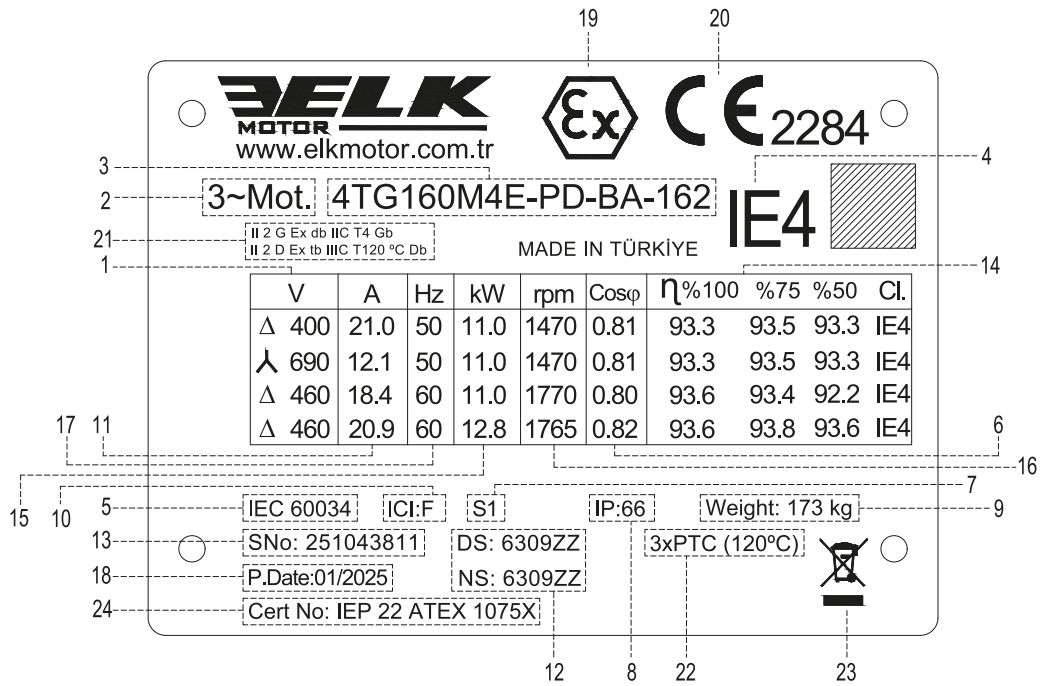

1. Rated Voltage	13. Serial Number
2. Motor Type: 3 Phase Asynchronous	14. Efficiency
3. Motor Code	15. Output Power
4. Efficiency Class	16. Speed
5. Manufacture Standard	17. Frequency
6. Power Factor	18. Production Date
7. Duty Cycle	19. Ex-Proof Logo
8. Protection Class	20. CE Mark
9. Motor Weight	21. ATEX Classification Codes
10. Insulation Class	22. 3xPTC Thermistor
11. Rated Current	23. WEEE Symbol
12. Bearing Type	24. Certificate Number



The nameplate shows the identification, and the most important technical data. The nameplate also defines the limits of proper usage, and manufacturing year of the motors. The first two digits in the serial number, shows the manufacturing year. For example, 25XXXXXXX shows that the product is manufactured in 2025.

## Zone 2-22 Exproof Motors Spare Parts

All the standard Zone 2/22 Exproof motors are produced by ELK MOTOR consist of the following main parts;

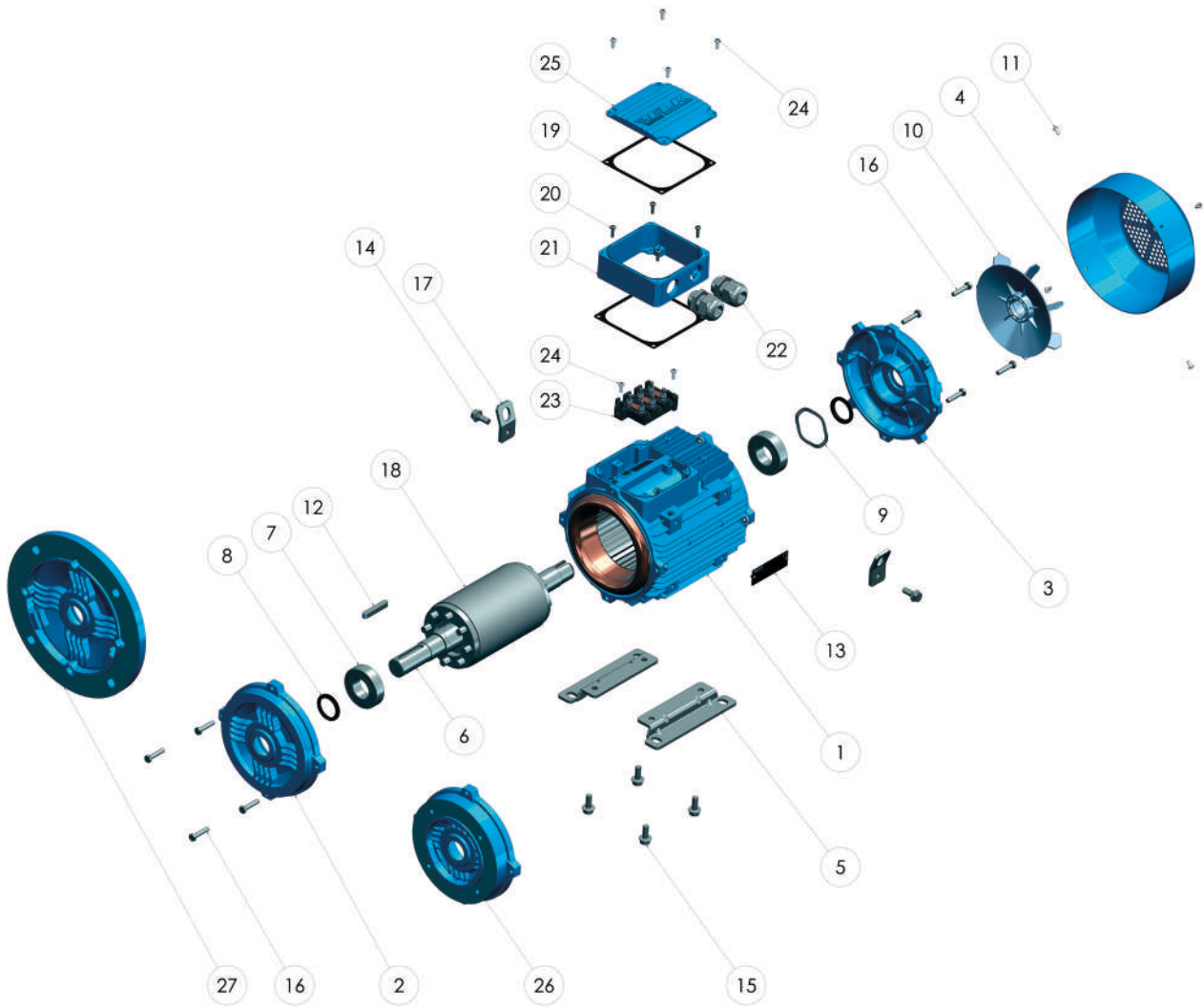

1. Housing

2. End Shield (DE)

3. End Shield (NDE)

4. Fan Cover

5. Mounting Foot

6. Shaft

7. Bearing

8. Shaft Seal

9. Spring Washer

10. Fan

11. Screw

12. Key

13. Nameplate

14. Screw

15. Screw

16. Bolt

17. Lifting Lug

18. Squirrel Cage Rotor

19. Terminal Box Gasket

20. Screw

21. Terminal Box

22. ATEX Cable Gland (Metal)

23. Terminal

24. Screw

25. Terminal Box Cover

26. B14 Flange

27. B5 Flange

While ordering spare parts, the motor serial number, full type designation and product code, as stated on the nameplate, must be specified. For field service, spare parts and additional information, please contact us.

In an Ex-Proof motor, spare parts that protect the internal volume must not be replaced by individuals or organizations without a module E certificate. Replacement of these critical parts should be carried out by authorized companies or manufacturers with the relevant certification.

## Zone 1-21 Exproof Motors Spare Parts

All the standard Zone 1/21 Exproof motors are produced by ELK MOTOR consist of the following main parts;

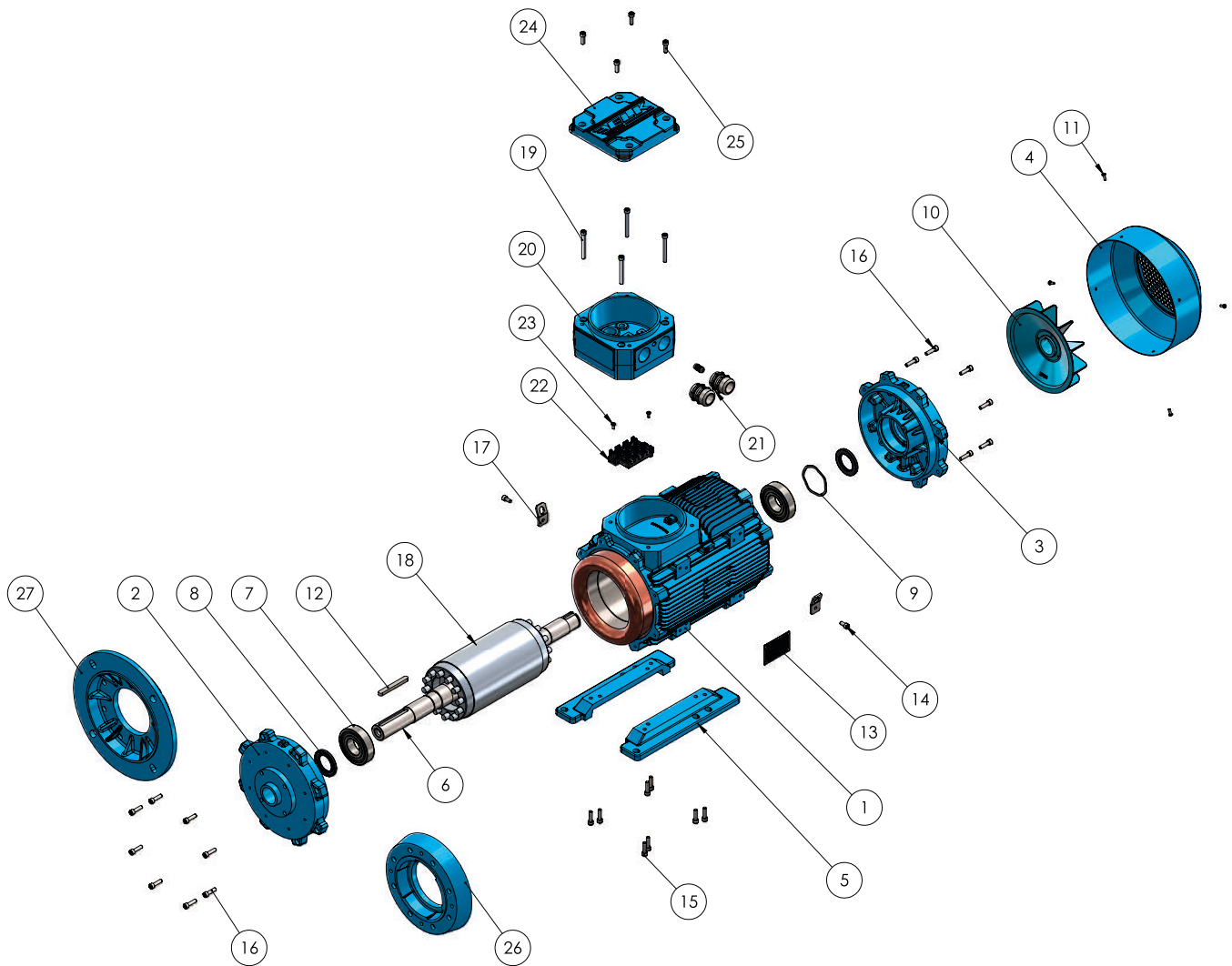

1. Housing
2. End Shield (DE)
3. End Shield (NDE)
4. Fan Cover
5. Mounting Foot
6. Shaft
7. Bearing
8. Shaft Seal
9. Spring Washer
10. Fan
11. Screw
12. Key
13. Nameplate
14. Bolt

15. Bolt
16. Bolt
17. Lifting Lug
18. Squirrel Cage Rotor
19. Screw
20. Terminal Box
21. ATEX Cable Gland (Metal)
22. Terminal
23. Screw
24. Terminal Box Cover
25. Screw
26. B14 Flange
27. B5 Flange

While ordering spare parts, the motor serial number, full type designation and product code, as stated on the nameplate, must be specified. For field service, spare parts and additional information, please contact us.

In an Ex-Proof motor, spare parts that protect the internal volume must not be replaced by individuals or organizations without a module E certificate. Replacement of these critical parts should be carried out by authorized companies or manufacturers with the relevant certification.

**ACCESSORIES**

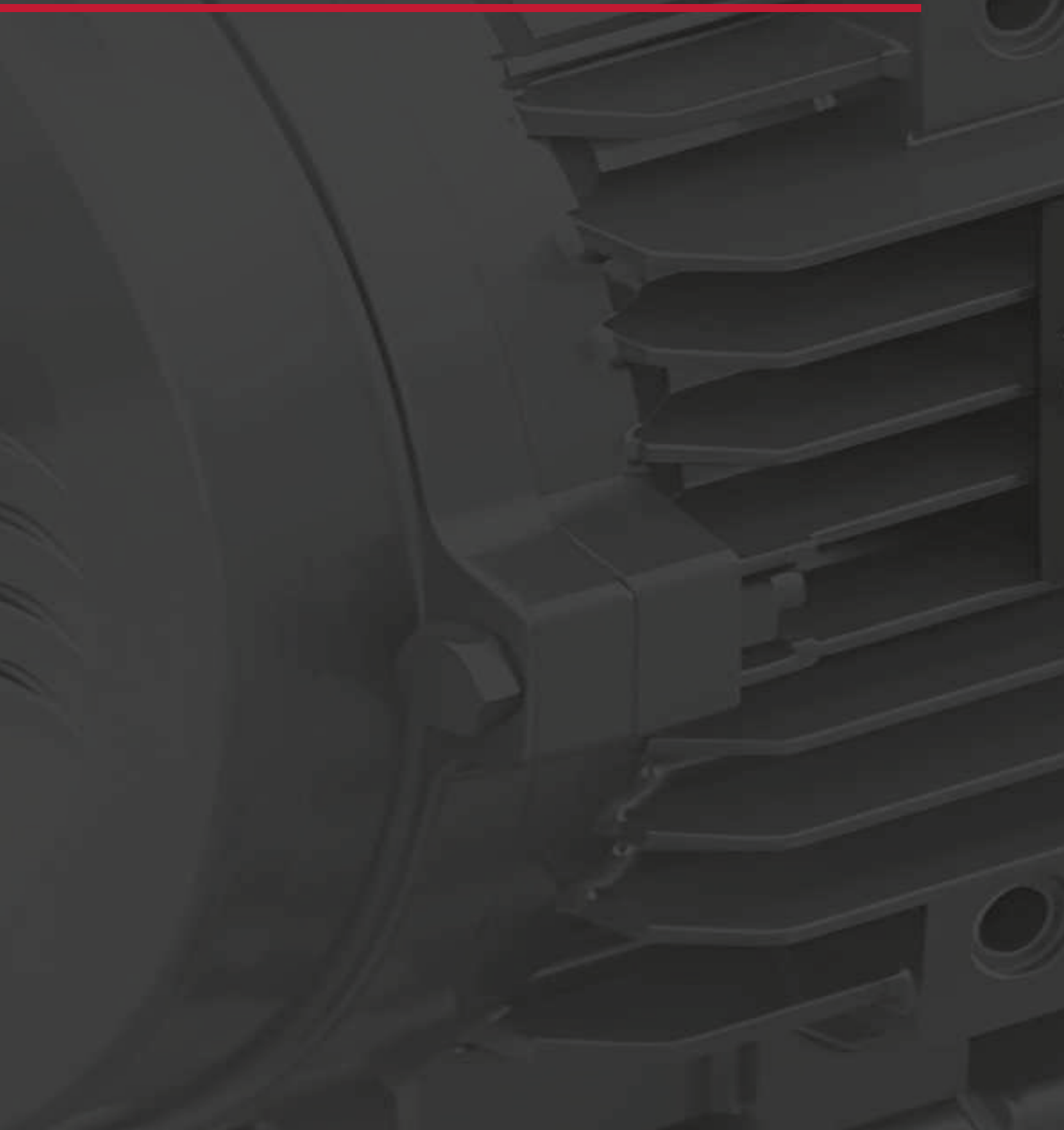

## PTC Thermistor and Thermal Switch

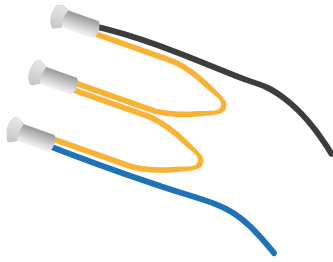

### Thermistor

Thermistor (PTC) is a temperature-dependent resistor. Its resistance increases after defined threshold temperature value to signal outside of an over-heating and/or over-loading condition. The thermistor must be evaluated with a proper electronics and/or a VSD with thermistor inputs.

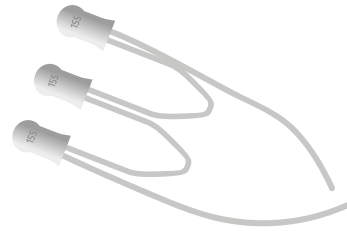

### Thermostat

A thermostat (PTO) functions in a way that is fundamentally similar to PTC thermistors; however, unlike PTC thermistors, thermostats provide voltage-free contacts that can be directly used to switch off a circuit, provided the current capacity of the thermostat is not exceeded.

## Anti-Condensation Space Heater and Drainage

In environments with high humidity, condensation may occur inside the motor. To prevent this, space heaters are wrapped around the motor windings to maintain a consistent temperature.

Additionally, drainage holes are provided in the motor body to prevent water accumulation and mitigate the risk of condensation.

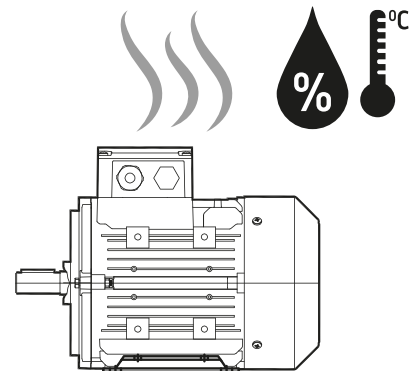

## NDE Shaft and Canopy

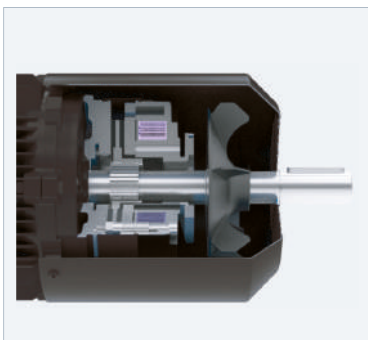

### NDE Shaft Extension

Non drive end shaft is used when it is desired to transfer the motor power to a second load or to manually rotate it when the motor is not energized.



### Canopy

It is used for operation in the outside environment where the motor fan is pointing upwards. This prevents the rainwater from entering the motor housing.

## Brake, Hand Release, Separately Driven Fan Encoder and Backstop

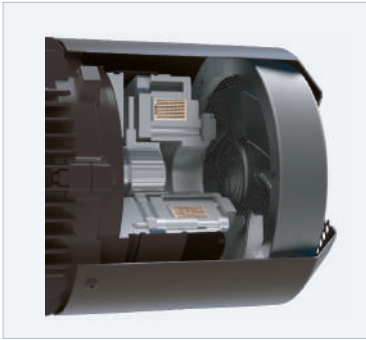

### Electromagnetic Brake

For each motor size, we offer a NDE mounted electromagnetic brake option. Brakes with supply voltages of 24V, 230V, and 400V DC, ranging from 5Nm to 1600Nm, are available and can be selected according to the specific needs.

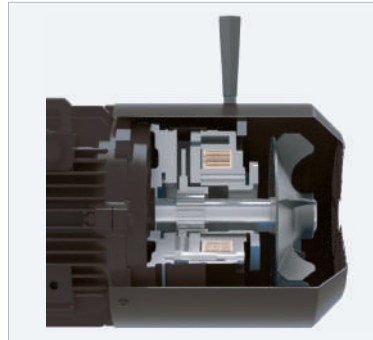

### Brake with Hand Release

In case of a power failure or when the brake needs to be released without applying electricity, it is used to release the system by overcoming the braking force through the lever on the brake.

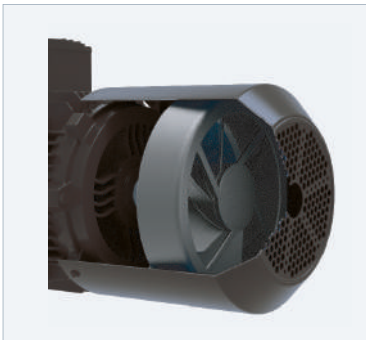

### Separately Driven Fan

In applications with variable-speed drives where the motor's speed is reduced, the efficiency of the motor fan's cooling decreases. The required cooling airflow is provided by a force cooling fan connected to the motor casing.



### Separately Driven Fan with Encoder

In applications where closed loop speed/torque control is required, a NDE mounted encoder can be used. Since the encoder is mounted on the motor's NDE end-shield, the motor fan cannot be used. Therefore, force cooling fan is also provided for the motor.

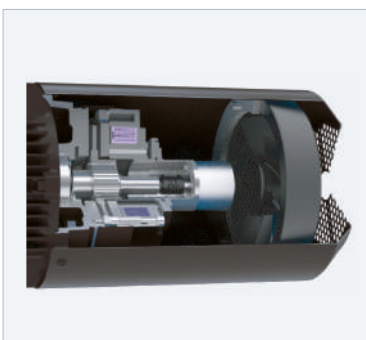

### Separately Driven Fan with Brake and Encoder

In applications requiring both braking and synchronous operation, the brake, encoder, and forced fan options are all provided as rear-mounted components on the motor.

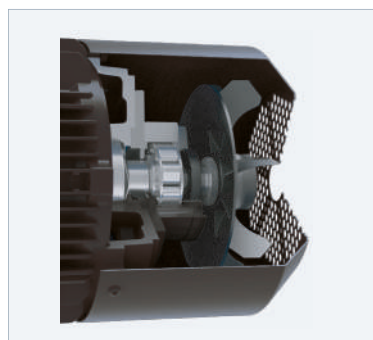

### Backstop

Backstop is used in situations where movement is desired in one direction and must be prevented in the opposite direction when the motor stops. The backstop option integrated into the rear motor housing is commonly used.









## Mass production for the entire world



### Sales Office / Factory

Yıldırım Beyazıt OSB Mah. 7. Cad.  
No: 71/1, 59500 Çerkezköy/Tekirdağ/Türkiye  
Phone: 444 95 60

### Headquarters

Atatürk Mah, Lozan Cad, No: 17  
34522 Esenyurt, İstanbul/Türkiye

elkmotor@elkmotor.com.tr  
www.elkmotor.com.tr

### Extention Offices

**Netherlands**  
Sales Office / Warehouse  
ELK Motor Benelux BV:  
Instraat 11 6021AC Budel  
T: +31 (0) 495 700258  
www.elkmotor.nl  
info@elkmotor.nl

**Italy**  
Sales Office / Warehouse  
ELK ITALIA S.r.L.  
Via Marsala 3 20900 Monza  
T: +39 02 38312078  
www.elkmotor.it  
info@elkmotor.it

**Japan**  
Sales Office  
1624-1 Ichinomiya, Tomioka,  
Gunma, Japan  
T: +81 70 4445 4968  
www.elkmotor.co.jp  
umit.kuhak@elkmotor.com.tr

